



CASED AXIAL JM AEROFOIL

PRODUCT FACTS

- Air flow up to 20.9 m³/s
- Static pressures up to 1100 Pa
- Fans tested to ISO5801 and BS848
- High energy efficiency
- Low installed noise levels
- Motor protection and terminal block IP55
- Larger sizes available please enquire for more information

ELECTRICAL SUPPLY

220-240V/50Hz/1φ & 380-420V/50Hz/3φ

TEMPERATURE RANGE

-40°C to 50°C as standard. 50°C to 70°C must be run at full speed only.

SIZES

315, 355, 400, 450, 500, 560, 630, 710, 800, 900 & 1000 mm

IMPELLERS

A unique high efficiency aerofoil section blade with a smoothed hub and clamp plate for adjustable pitch angle availability.

Woods impellers are all high pressure die cast to offer thin aerofoil sections for low generation of noise. Every cast aluminium component is X-ray examined using Real Time Radiography inspection prior to assembly. The maximum pitch angles shown allow for speed control by frequency inverter (3ph only).

MOTORS

All motors are totally enclosed air stream rated class F insulation. Constructed from aluminium or cast iron as standard with special 'T' slot, or pad mounted fixings. Single speed motors are suitable for speed control by voltage regulation where indicated. Three phase motors are suitable for use with frequency inverters, suitable for turn down to 20% of maximum speed. Two speed motors are available on request. Suitable for horizontal or vertical shaft operation. Supplied IP55, with removable drain plugs.

Sealed for life bearings lubricated with wide temperature range grease. The BT and CT frames are fitted with overheat protection thermostat as standard. 80-160 frame motors are fitted with Thermistor DHP. These motors are suitable for inverter/speed control down to 20% of full speed and where within scope incorporate IE2 compliant motors.



CASING

JM Aerofoil fans are available in either a long cased form, complete with an externally mounted pre-wired electrical terminal box, or short cased for duct or plate installation. Casings are spun from sheet steel with integral pre-drilled and radiused inlet flanges. The galvanised finish gives a high resistance to corrosion and is ideal for external as well as internal use.

PRODUCT CODE

63JM/20/4/6/36

- 63 - denotes the fan impeller diameter in centimetres
- JM - denotes fan type
- 20 - denotes impeller hub diameter in centimetres
- 4 - denotes a nominal 4 pole speed
- 6 - denotes the number of blades
- 36 - denotes the pitch angle for the required duty

ACCESSORIES (Pages 230-237) - CONTROLLERS (Pages 249-297)



Damper

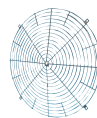

Guard



Bellmouth



Flange



Mounting Feet



Rubber AV's



Acoustic Jacket



Flexible Connector



Silencer



Controls Transformer



Controls Electronic



Controls Inverter

JM AEROFOIL PERFORMANCE AND ELECTRICAL DATA

220-240V/50HZ/1 ϕ - L TYPE

PERFORMANCE CHART - 315-630MM

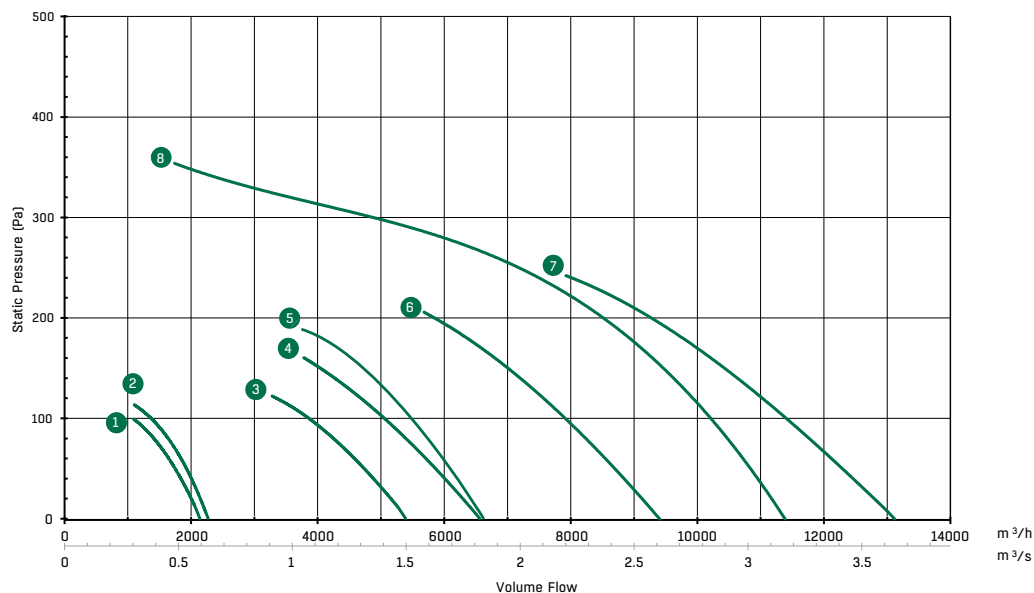

PERFORMANCE TABLE - 315-630MM

Ref	Ref	m ³ /s @ Pa (Static)						
		0	50	100	150	200	250	300
1	31JM/16/4/5/34	0.59	0.48					
2	35JM/16/4/5/22	0.63	0.53	0.37				
3	40JM/16/4/5/40	1.5	1.31	1.07				
4	45JM/16/4/5/30	1.82	1.62	1.4	1.12			
5	50JM/20/4/6/20	1.84	1.68	1.52	1.3			
6	50JM/20/4/6/32	2.61	2.41	2.19	1.94	1.62		
7	56JM/20/4/6/30	3.64	3.41	3.16	2.89	2.57		
8	63JM/20/4/6/16	3.17	3.01	2.82	2.61	2.38	1.99	1.33

PRODUCT AND ELECTRICAL DETAILS - 315-630MM

Ref	Product Code	Product Number	Pitch Angle (°)		Speed rev/min	Motor	Rating (kW)	Full Load Current (A)	Starting Current (A)	Wiring Diagram (CD)	Speed Controller	
			Min	Max							Electronic	Transformer
1	31JM/16/4/5/34	EJ321460	28	34	1420	BT5	0.075	0.5	1.45	CD3038	ME1.1	TEID 1
2	35JM/16/4/5/22	EJ361460	18	22	1420	BT5	0.075	0.5	1.45	CD3038	ME1.1	TEID 1
3	40JM/16/4/5/40	EJ411452	34	40	1420	BT9	0.25	1.6	3.45	CD3038	ME1.3	TEID 2.2
4	45JM/16/4/5/30	EJ461466	24	30	1420	BT9	0.32	2.2	5	CD3038	ME1.3	TEID 2.2
5	50JM/20/4/6/20	DX511455	16	20	1420	BT9	0.32	2.2	5	CD3038	ME1.3	TEID 2.2
6	50JM/20/4/6/32	EJ511466	32	32	1420	CT9	0.68	4.8	11	CD3038	ME1.6	TEID 5
7	56JM/20/4/6/30	DX571459	26	30	1420	CT9	0.97	6.9	13.5	CD3037	ME1.6	TEID 7.5A
8	63JM/20/4/6/16	DX641453	14	16	1420	CT9	0.97	6.9	13.5	CD3037	ME1.6	TEID 7.5A

For ErP efficiency ratings and grades please refer to our Fan Selector for more information. For speed controllers please see pages 219-267.

Products in **bold** are available from our UK Distributors on next day delivery, if ordered by 4pm. Please call to confirm availability on 01206 222 580.





DRAWINGS - 315-355 MM

315 MM (EJ321460)

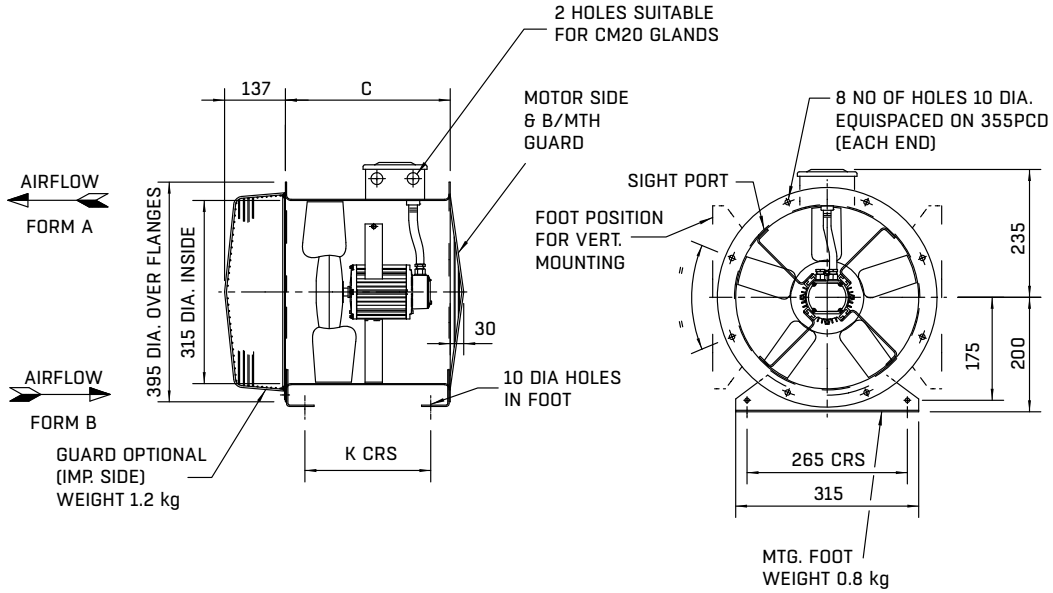

Size	Motor Frame	C	K	Weight kg Fan
315	BT5	330	245	21

355 MM (EJ361460)

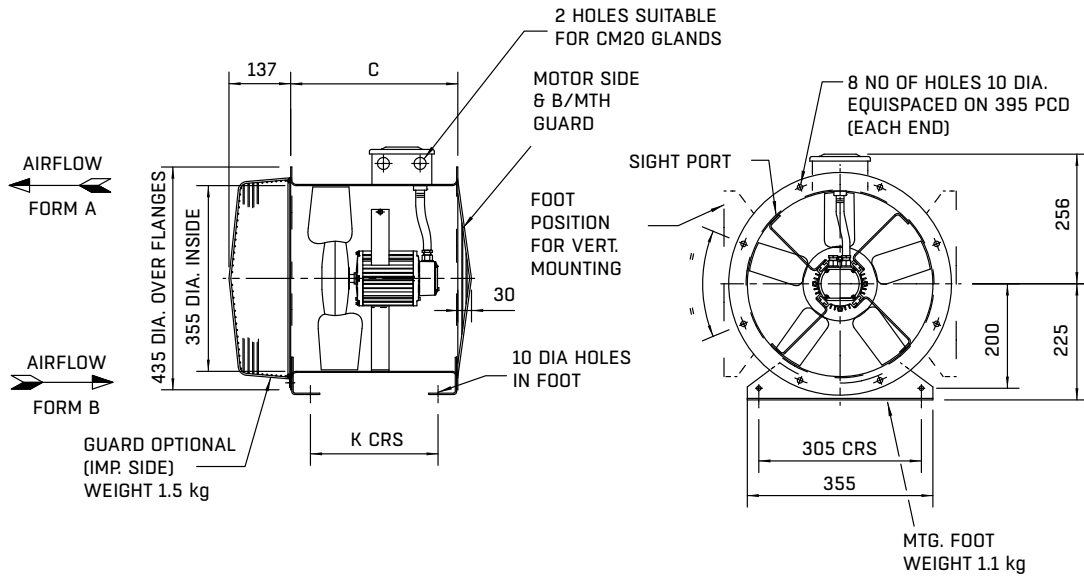

Size	Motor Frame	C	K	Weight kg Fan
355	BT5	330	245	22

All dimensions in mm.

DRAWINGS - 400-450 MM

400 MM (EJ411452)

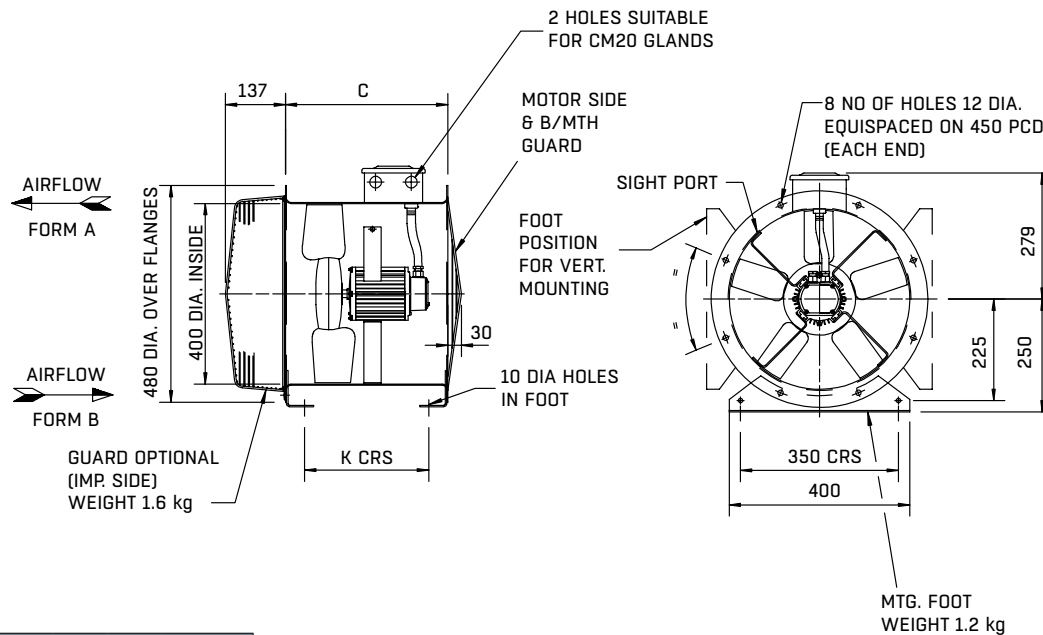

Size	Motor Frame	C	K	Weight kg Fan
400	BT9	375	290	25

450 MM (EJ461466)

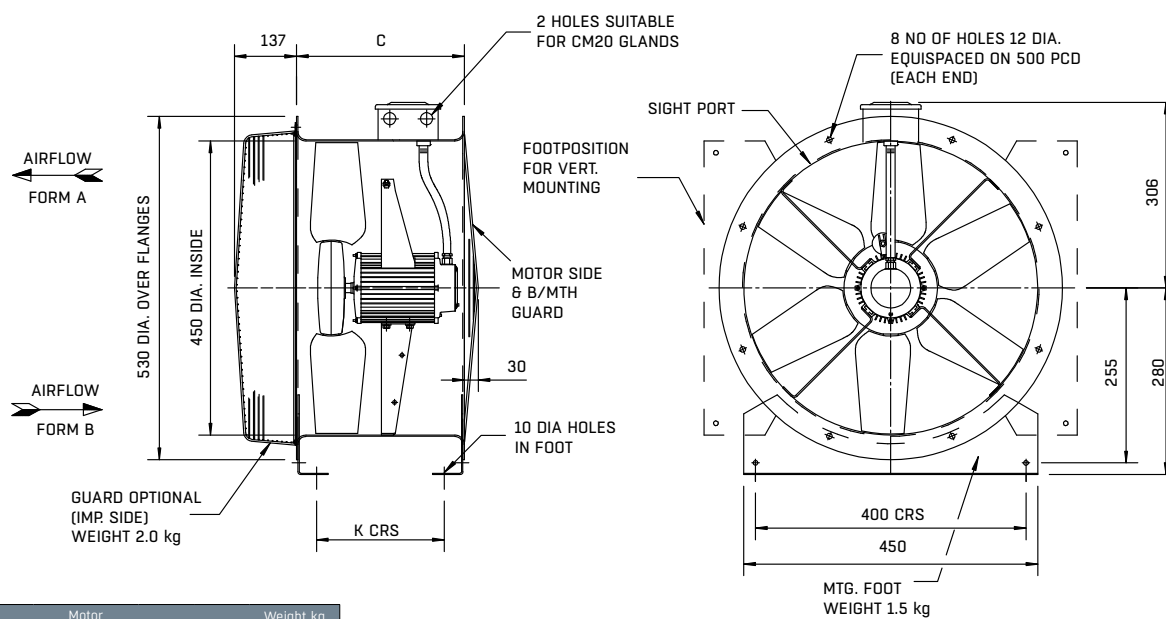

Size	Motor Frame	C	K	Weight kg Fan
450	BT9	330	245	26

All dimensions in mm.



DRAWINGS - 500-560 MM

500 MM (DX511455 & EJ511466)

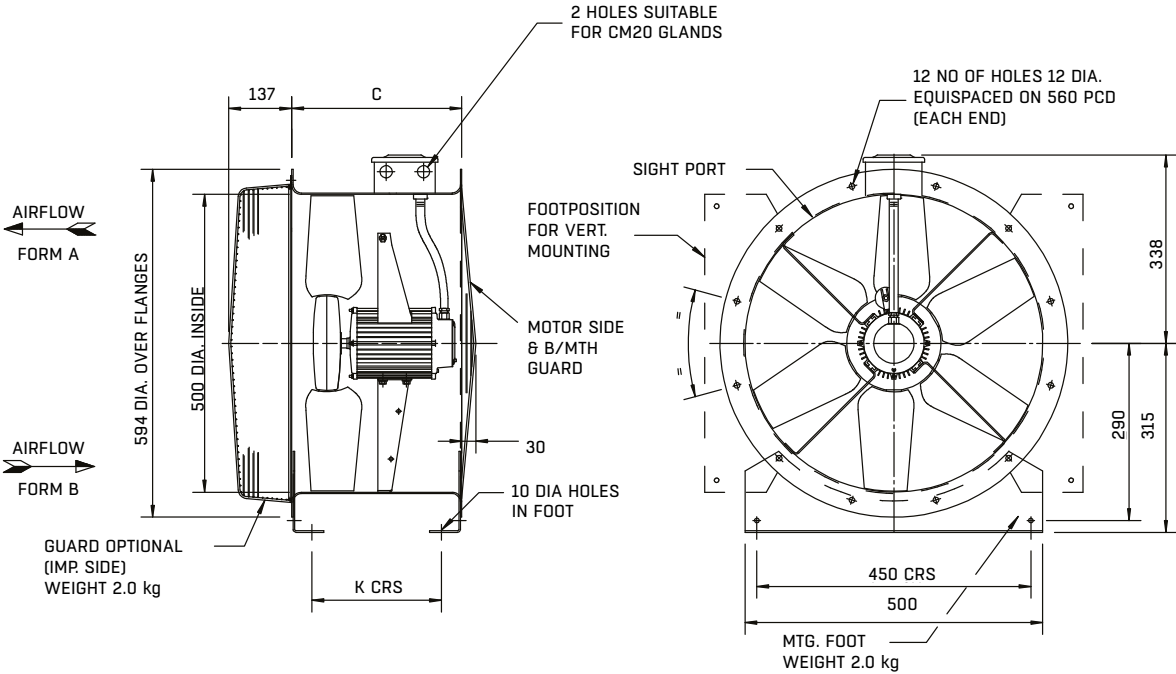

Part Number	Size	Motor Frame	C	K	Weight kg Fan
DX511455	500	BT9	375	290	34
EJ511466	500	CT9	330	245	34

560 MM (DX571459)

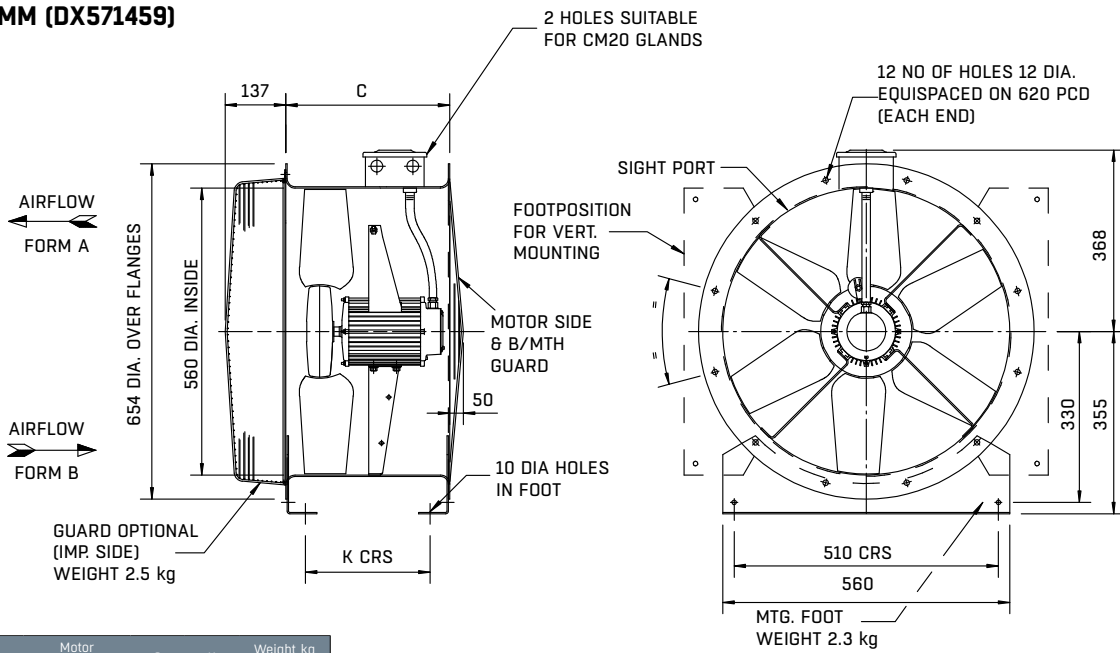

Size	Motor Frame	C	K	Weight kg Fan
560	CT9	375	290	38

All dimensions in mm.

DRAWING - 630 MM

630 MM (DX641453)

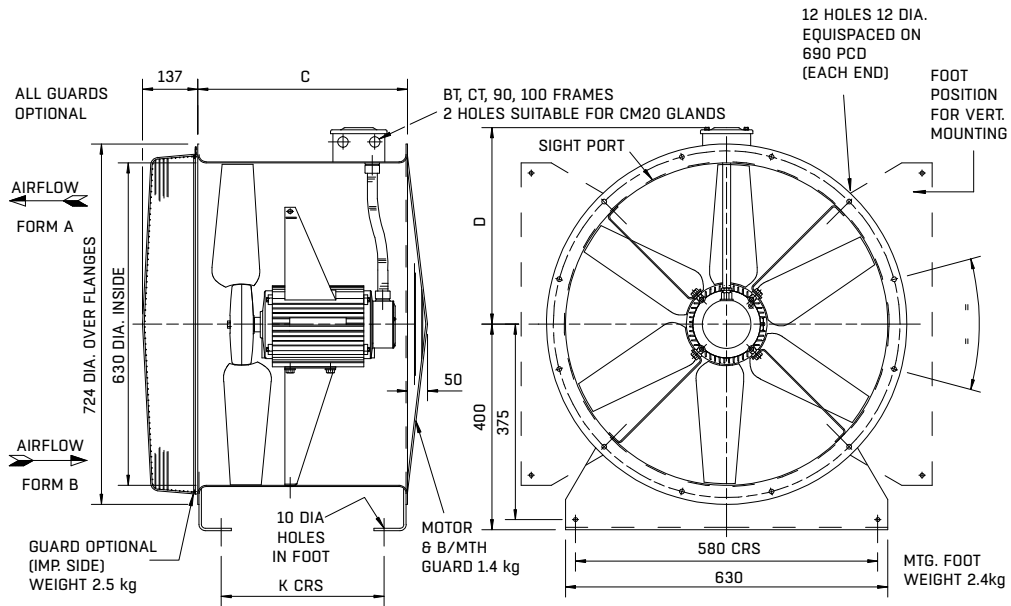

Size	Motor Frame	C	D	K	Weight kg Fan
630	CT9	375	403	290	52

All dimensions in mm.



JMv AEROFOIL PERFORMANCE AND ELECTRICAL DATA

380-420V/50HZ/3 ϕ - L TYPE

PERFORMANCE CHART - 315-355MM, 2 POLE

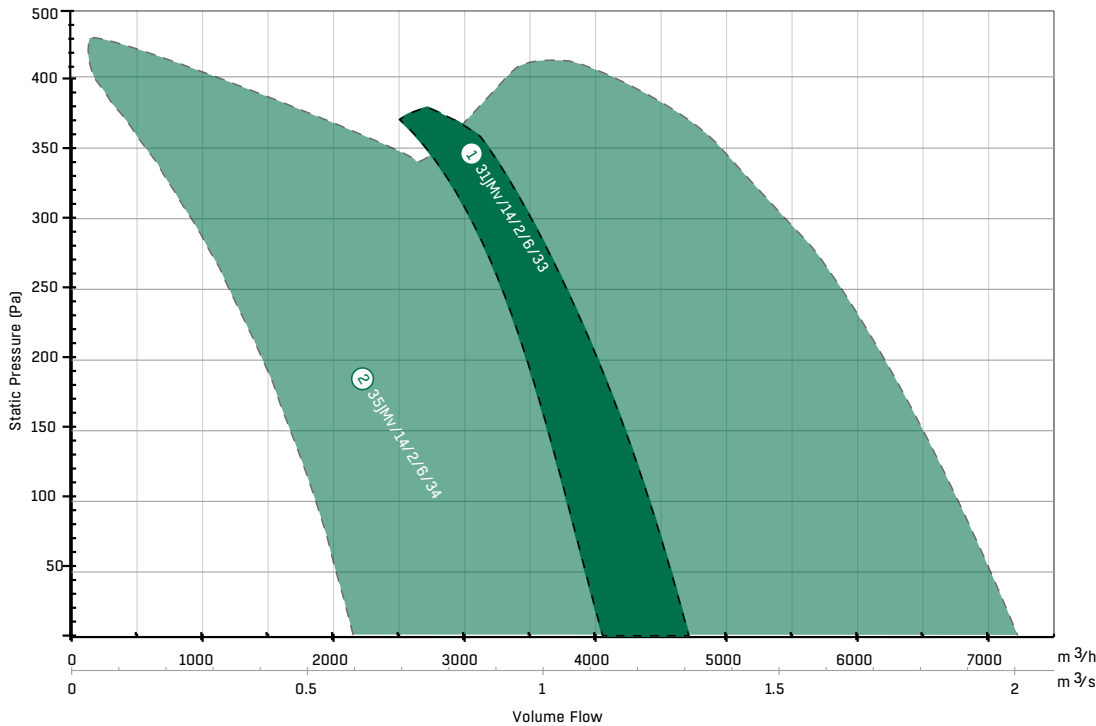

As standard 3 phase JM Aerofoils are supplied at the maximum pitch angle, the envelope curve above illustrates the pitch angle range available on request.

PERFORMANCE TABLE - 315-355 MM, 2 POLE

Ref	Product Code	m ³ /s @ Pa (Static)																	
		0	25	50	75	100	125	150	175	200	225	250	275	300	325	350	375	400	
1	31JMv/14/2/6/33	1.26	1.24	1.22	1.2	1.17	1.14	1.12	1.09	1.06	1.03	0.99	0.96	0.92					
2	35JMv/14/2/6/34	1.88	1.85	1.82	1.79	1.75	1.72	1.68	1.65	1.61	1.57	1.53	1.49	1.45	1.41	1.36	1.32	1.27	

PRODUCT AND ELECTRICAL DETAILS - 315-355 MM, 2 POLE

Ref	Product Code	Product Number	Pitch Angle (°)		Speed rev/min	Motor	Rating (kW)	Full Load Current (A)	Starting Current (A)	Wiring Diagram (CD)	Speed Controller			Sound Levels
			Min	Max							Electronic	Transformer	Inverter	
1	31JMv/14/2/6/33	JV346202	25	33	2760	BT9	0.58	1.45	5.7	CD3020	N/A	N/A	IDDXF54 2.2	63
2	35JMv/14/2/6/34	JV386201	31	34	2760	80	1.32	2.79	14.5	CD3020	N/A	N/A	IDDXF54 3.7	65

For ErP efficiency ratings and grades please refer to our Fan Selector for more information. Sound pressure levels quoted are at the inlet, and are average dBA at 3m distance over a sphere at the mid point at the highest angle given, under free field conditions. These are presented for comparative purposes only. For speed controllers please see pages 219-267.

Non stocked JM Aerofoil are available in 10 working weeks, based on the parts availability. If a reduced lead time is required please contact the office.

Products in **bold** are available from our UK Distributors on next day delivery, if ordered by 4pm. Please call to confirm availability on 01206 222 580.



JM AEROFOIL PERFORMANCE AND ELECTRICAL DATA

380-420V/50HZ/3 ϕ - L TYPE

PERFORMANCE CHART - 315-355 MM, 4 POLE

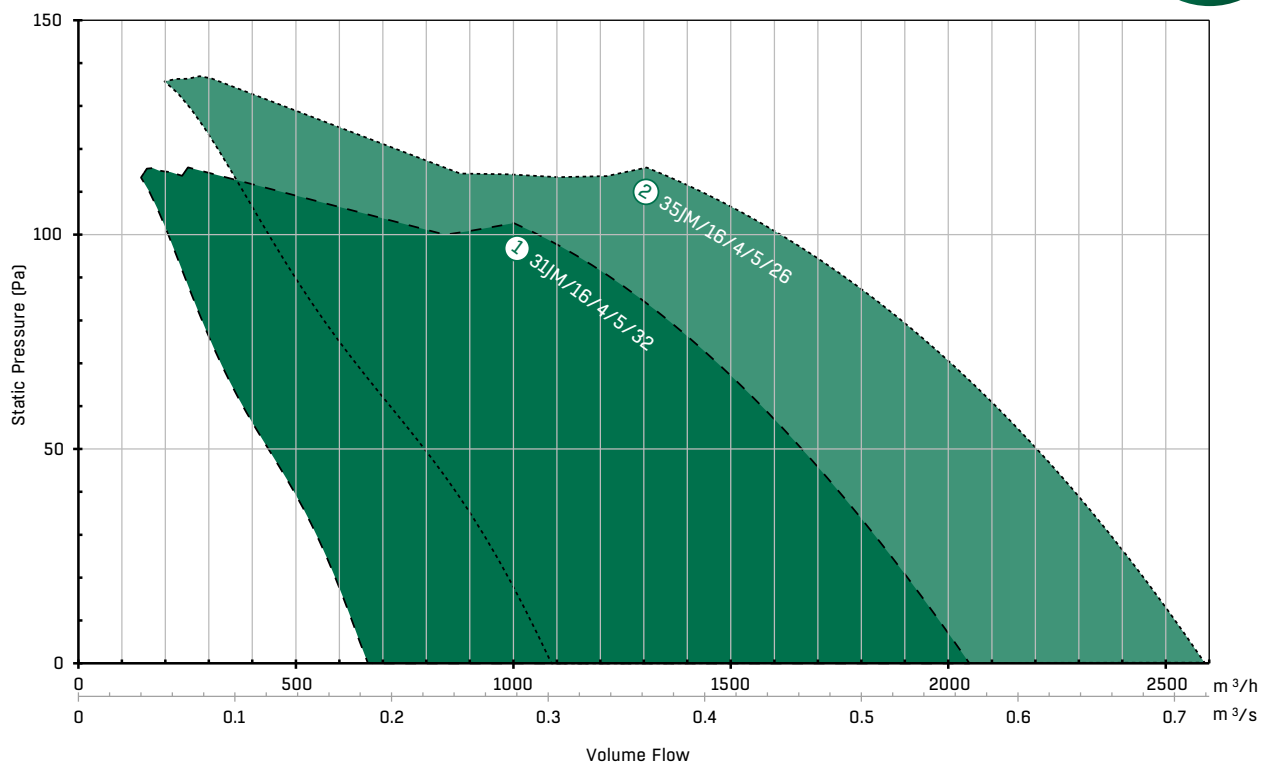

As standard 3 phase JM Aerofoils are supplied at the maximum pitch angle, the envelope curve above illustrates the pitch angle range available on request.

PERFORMANCE TABLE - 315-355 MM, 4 POLE

Ref	Product Code	m ³ /s @ Pa (Static)		
		0	50	100
1	31JM/16/4/5/32	0.56	0.46	0.29
2	35JM/16/4/5/26	0.71	0.61	0.44

PRODUCT AND ELECTRICAL DETAILS - 315-355 MM, 4 POLE

Ref	Product Code	Product Number	Pitch Angle (°)		Speed rev/min	Motor	Rating (kW)	Full Load Current (A)	Starting Current (A)	Wiring Diagram (CD)	Speed Controller			Sound Levels
			Min	Max							Electronic	Transformer	Inverter	
1	31JM/16/4/5/32	EJ341460	8	32	1420	BT4 (IE1)	0.087	0.35	1.12	CD2416	N/A	TDID 2.5A	IDDXF54-2.2	42
2	35JM/16/4/5/26	EJ381460	8	26	1420	BT4 (IE1)	0.1	0.36	1	CD2416	N/A	TDID 2.5A	IDDXF54-2.2	43

For ErP efficiency ratings and grades please refer to our Fan Selector for more information. Sound pressure levels quoted are at the inlet, and are average dBA at 3m distance over a sphere at the mid point at the highest angle given, under free field conditions. These are presented for comparative purposes only. For speed controllers please see pages 250-297.

Non stocked JM Aerofoil are available in 10 working weeks, based on the parts availability. If a reduced lead time is required please contact the office.

Products in **bold** are available from our UK Distributors on next day delivery, if ordered by 4pm. Please call to confirm availability on 01206 222 580.





DRAWINGS - 315-355 MM

315 MM (JV346202)

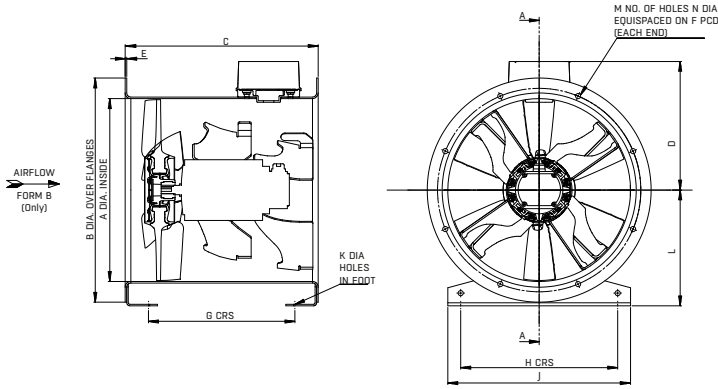

Product Number	Size	Motor frame	A	B	C	D	E	F	G	H	J	K	L	M	N	Weight kg Fan
JV346202	315	BT4	315	395	375	229.5	3	355	285	265	315	10	200	8	10	23

315 MM (EJ341460)

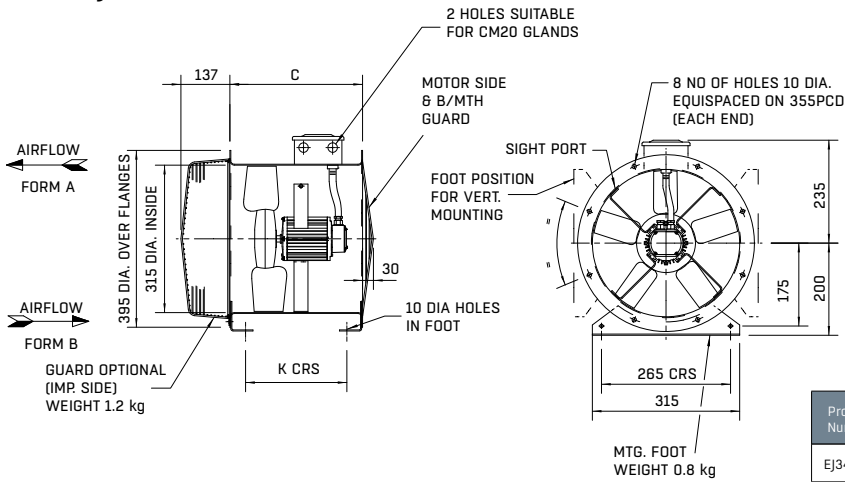

Product Number	Size	Motor Frame	C	K	Weight kg Fan
EJ341460	315	BT4	330	245	22

355 MM (EJ381460)

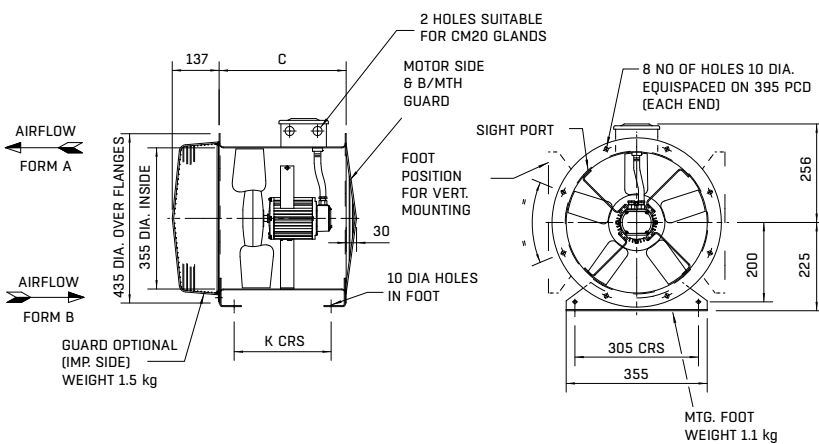

Product Number	Size	Motor Frame	C	K	Weight kg Fan
EJ381460	355	BT9	330	245	34

All dimensions in mm.

JM AEROFOIL PERFORMANCE AND ELECTRICAL DATA

380-420V/50HZ/3 ϕ - L TYPE

PERFORMANCE CHART - 400-450 MM, 2 POLE

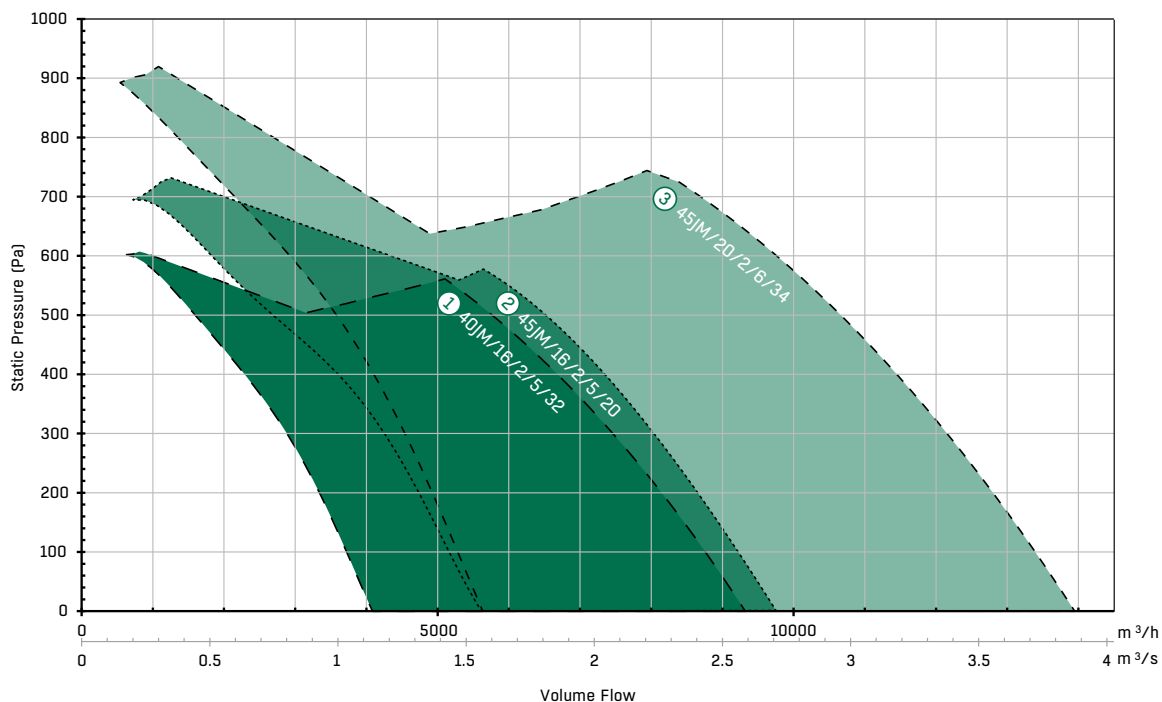

As standard 3 phase JM Aerofoils are supplied at the maximum pitch angle, the envelope curve above illustrates the pitch angle range available on request.

PERFORMANCE TABLE - 400-450 MM, 2 POLE

Ref	Product Code	m ³ /s @ Pa (Static)										
		0	50	100	150	200	250	300	400	500	600	700
1	40JM/16/2/5/32	2.58	2.51	2.43	2.35	2.26	2.17	2.07	1.85	1.6		
3	45JM/16/2/5/20	2.7	2.63	2.56	2.48	2.4	2.32	2.23	2.04	1.81		
2	45JM/20/2/6/34	3.87	3.79	3.72	3.63	3.55	3.46	3.37	3.18	2.96	2.71	2.41

PRODUCT AND ELECTRICAL DETAILS - 400-450 MM, 2 POLE

Ref	Product Code	Product Number	Pitch Angle (°)		Speed rev/min	Motor	Rating (kW)	Full Load Current (A)	Starting Current (A)	Wiring Diagram (CD)	Speed Controller			Sound Levels
			Min	Max							Electronic	Transformer	Inverter	
1	40JM/16/2/5/32	EJ431273	10	32	2840	80 (IE2)	1.73	3.59	18.3	CD2416	N/A	N/A	IDDXF54-3.7	61
2	45JM/16/2/5/20	EE481272	8	20	2840	80 (IE2)	1.73	3.59	18.3	CD2416	N/A	N/A	IDDXF54-3.7	66
3	45JM/20/2/6/34	EJ481275	10	34	2910	100L (IE2)	3.6	7.1	45.44	CD2416	N/A	N/A	IDDXF54-7.2	72

For ErP efficiency ratings and grades please refer to our Fan Selector for more information. Sound pressure levels quoted are at the inlet, and are average dBA at 3m distance over a sphere at the mid point at the highest angle given, under free field conditions. These are presented for comparative purposes only. For speed controllers please see pages 250-297.

Non stocked JM Aerofoil are available in 10 working weeks, based on the parts availability. If a reduced lead time is required please contact the office.

Products in **bold** are available from our UK Distributors on next day delivery, if ordered by 4pm. Please call to confirm availability on 01206 222 580.





JMv AEROFOIL PERFORMANCE AND ELECTRICAL DATA

380-420V/50HZ/3 ϕ - L TYPE

PERFORMANCE CHART - 400-450 MM, 4 POLE

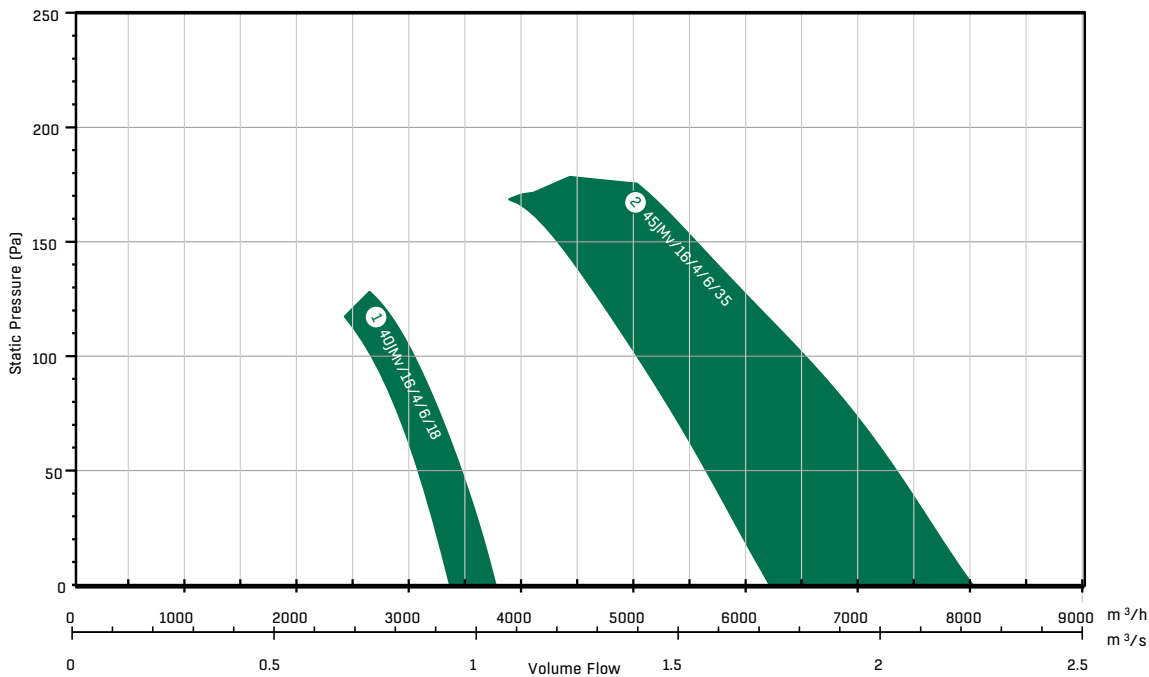

As standard 3 phase JM Aerofoils are supplied at the maximum pitch angle, the envelope curve above illustrates the pitch angle range available on request.

PERFORMANCE TABLE - 400-450 MM, 4 POLE

Ref	Product Code	m³/s @ Pa (Static)			
		0	50	100	150
1	40JMv/16/4/6/18	0.99	0.90	0.78	
2	45JMv/16/4/6/35	2.20	2.00	1.77	1.50

PRODUCT AND ELECTRICAL DETAILS - 400-450 MM, 4 POLE

Ref	Product Code	Product Number	Pitch Angle (°)		Speed rev/min	Motor	Rating (kW)	Full Load Current (A)	Starting Current (A)	Wiring Diagram (CD)	Speed Controller			Sound Levels
			Min	Max							Electronic	Transformer	Inverter	
1	40JMv/16/4/6/18	JV436452	14	18	1400	80	0.14	0.40	2.00	CD3020	N/A	N/A	IDDXF54-2.2	51
2	45JMv/16/4/6/35	JV486460	23	35	1400	80	0.66	1.49	7.37	CD3020	N/A	N/A	IDDXF54-2.2	57

For ErP efficiency ratings and grades please refer to our Fan Selector for more information. Sound pressure levels quoted are at the inlet, and are average dBA at 3m distance over a sphere at the mid point at the highest angle given, under free field conditions. These are presented for comparative purposes only. For speed controllers please see pages 250-297.

Non stocked JM Aerofoil are available in 10 working weeks, based on the parts availability. If a reduced lead time is required please contact the office.

Products in **bold** are available from our UK Distributors on next day delivery, if ordered by 4pm. Please call to confirm availability on 01206 222 580.



DRAWINGS - 400-450 MM 2 POLE

400 MM (EJ431273)

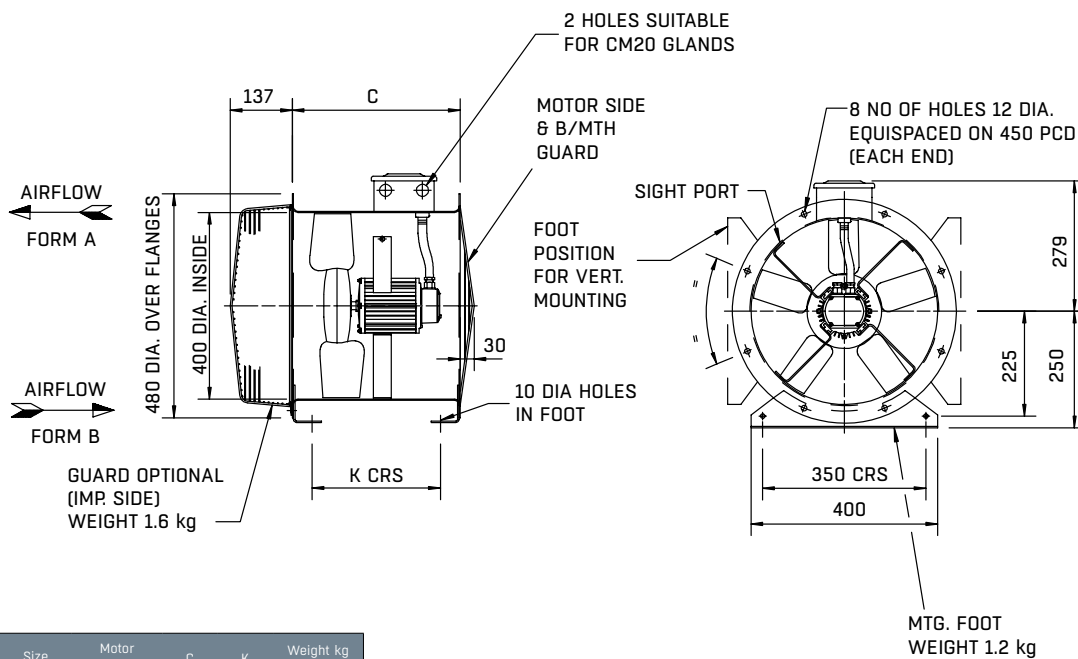

Product Number	Size	Motor Frame	C	K	Weight kg Fan
EJ431273	400	80	375	290	35

450 MM (EE481272 & EJ481275)

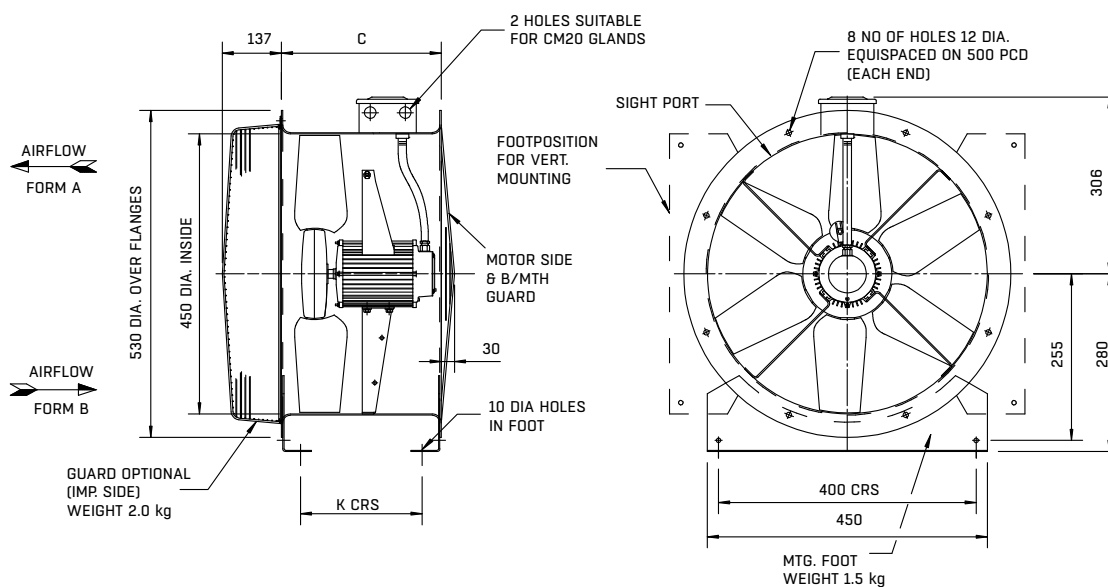

Product Number	Size	Motor Frame	C	K	Weight kg Fan
EE481272	450	80	375	290	37
EJ481275	450	100L	520	434	60

All dimensions in mm.



DRAWINGS - 400-450 MM 4 POLE

400 MM (JV436452 & JV486460)

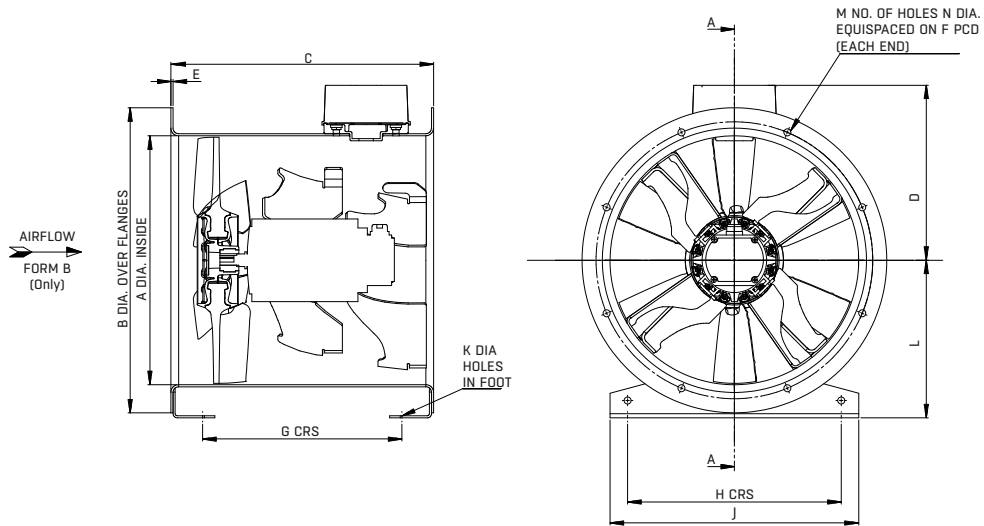

Product Number	Size	Motor frame	A	B	C	D	E	F	G	H	J	K	L	M	N	Weight kg Fan
JV436452	400	80	400	480	375	272	3	450	285	350	400	10	250	8	10	35
JV486460	450	80	450	530	375	297	3	500	275	400	450	10	280	8	12	36

All dimensions in mm.

JM AEROFOIL PERFORMANCE AND ELECTRICAL DATA

380-420V/50HZ/3 ϕ - L TYPE

PERFORMANCE CHART - 500 MM, 2 POLE

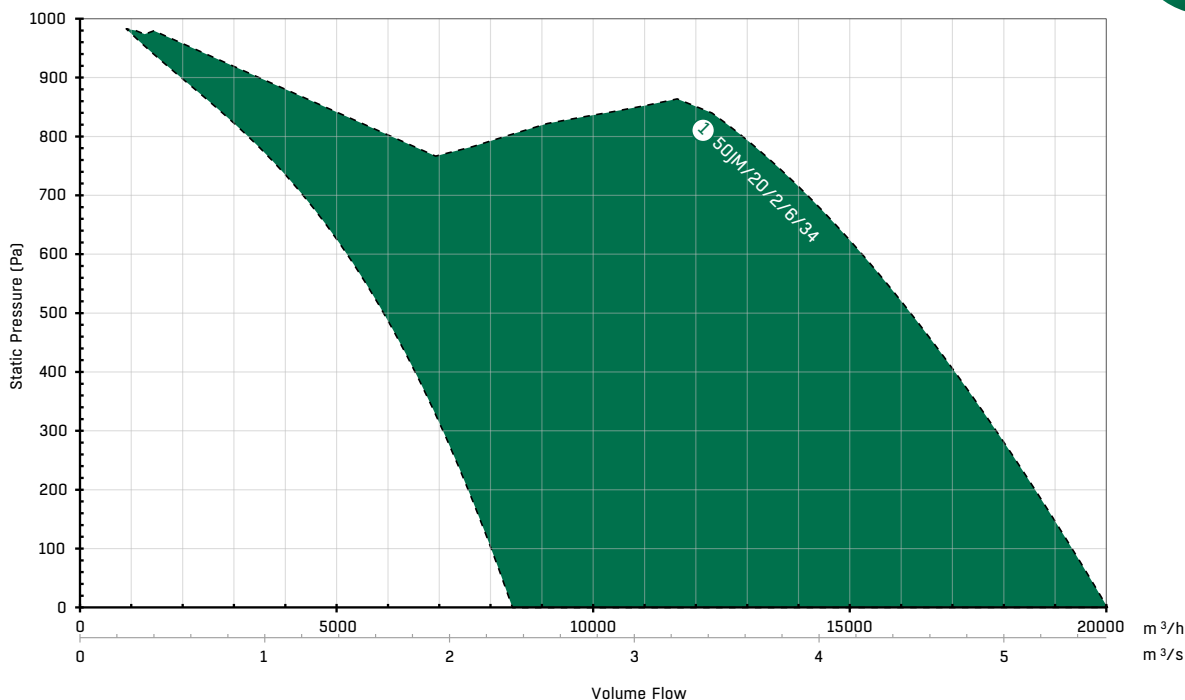

As standard 3 phase JM Aerofoils are supplied at the maximum pitch angle, the envelope curve above illustrates the pitch angle range available on request.

PERFORMANCE TABLE - 500 MM, 2 POLE

Ref	Product Code	m ³ /s @ Pa (Static)											
		0	50	100	150	200	250	300	400	500	600	700	800
1	50JM/20/2/6/34	5.56	5.46	5.36	5.27	5.16	5.06	4.95	4.73	4.49	4.23	3.93	3.58

PRODUCT AND ELECTRICAL DETAILS - 500 MM, 2 POLE

Ref	Product Code	Product Number	Pitch Angle (°)		Speed rev/min	Motor	Rating (kW)	Full Load Current (A)	Starting Current (A)	Wiring Diagram (CD)	Speed Controller			Sound Levels
			Min	Max							Electronic	Transformer	Inverter	
1	50JM/20/2/6/34	EJ531274	10	34	2910	112M (IE2)	6.2	11.7	77.2	CD2417	N/A	N/A	IDDXF54-12	75

For ErP efficiency ratings and grades please refer to our Fan Selector for more information. Sound pressure levels quoted are at the inlet, and are average dBA at 3m distance over a sphere at the mid point at the highest angle given, under free field conditions. These are presented for comparative purposes only. For speed controllers please see pages 250-297.

Non stocked JM Aerofoil are available in 10 working weeks, based on the parts availability. If a reduced lead time is required please contact the office.

Products in **bold** are available from our UK Distributors on next day delivery, if ordered by 4pm. Please call to confirm availability on 01206 222 580.





JM AEROFOIL PERFORMANCE AND ELECTRICAL DATA

380-420V/50HZ/3 ϕ - L TYPE

PERFORMANCE CHART - 500 MM, 4 POLE

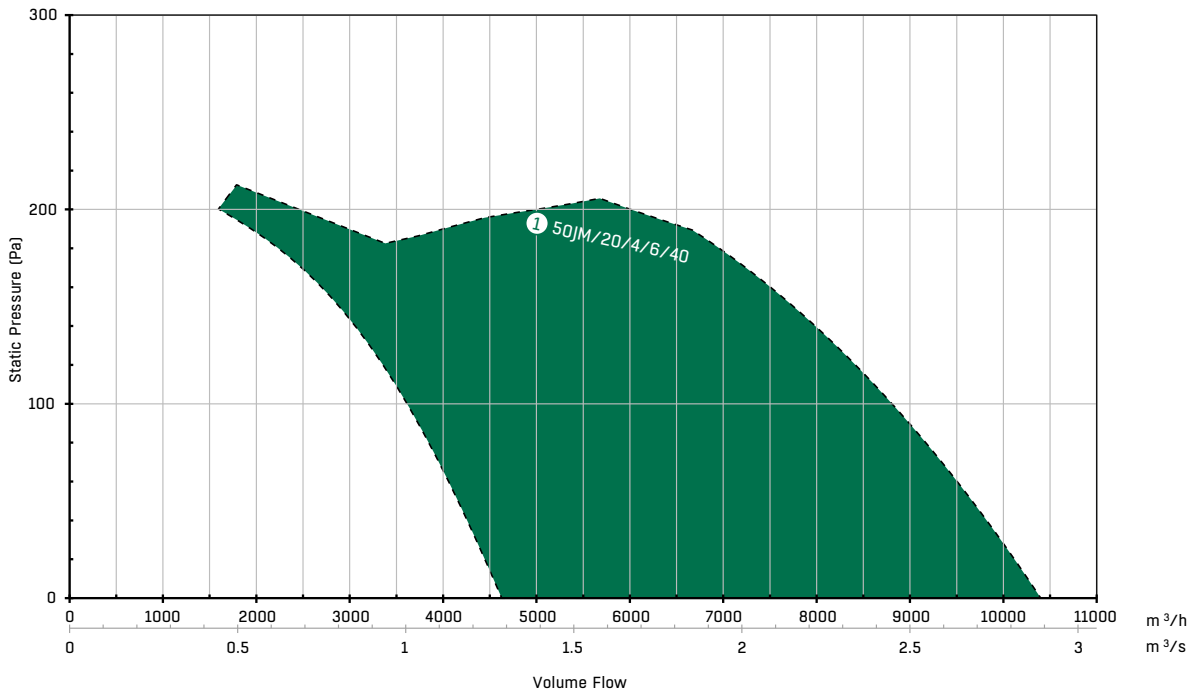

As standard 3 phase JM Aerofoils are supplied at the maximum pitch angle, the envelope curve above illustrates the pitch angle range available on request.

PERFORMANCE TABLE - 500 MM, 4 POLE

Ref	Product Code	m³/s @ Pa (Static)			
		0	50	100	150
1	50JM/20/4/6/40	2.96	2.76	2.52	2.21

PRODUCT AND ELECTRICAL DETAILS - 500 MM, 4 POLE

Ref	Product Code	Product Number	Pitch Angle (°)		Speed rev/min	Motor	Rating (kW)	Full Load Current (A)	Starting Current (A)	Wiring Diagram (CD)	Speed Controller			Sound Levels
			Min	Max							Electronic	Transformer	Inverter	
1	50JM/20/4/6/40	EJ531478	12	40	1420	80 (IE2)	0.9	1.92	9.79	CD2416	N/A	N/A	IDDXF54-2.2	59

For ErP efficiency ratings and grades please refer to our Fan Selector for more information. Sound pressure levels quoted are at the inlet, and are average dBA at 3m distance over a sphere at the mid point at the highest angle given, under free field conditions. These are presented for comparative purposes only. For speed controllers please see pages 250-297.

Non stocked JM Aerofoil are available in 10 working weeks, based on the parts availability. If a reduced lead time is required please contact the office.

Products in **bold** are available from our UK Distributors on next day delivery, if ordered by 4pm. Please call to confirm availability on 01206 222 580.



DRAWINGS - 500 MM

500 MM (EJ531274 & EJ531478)

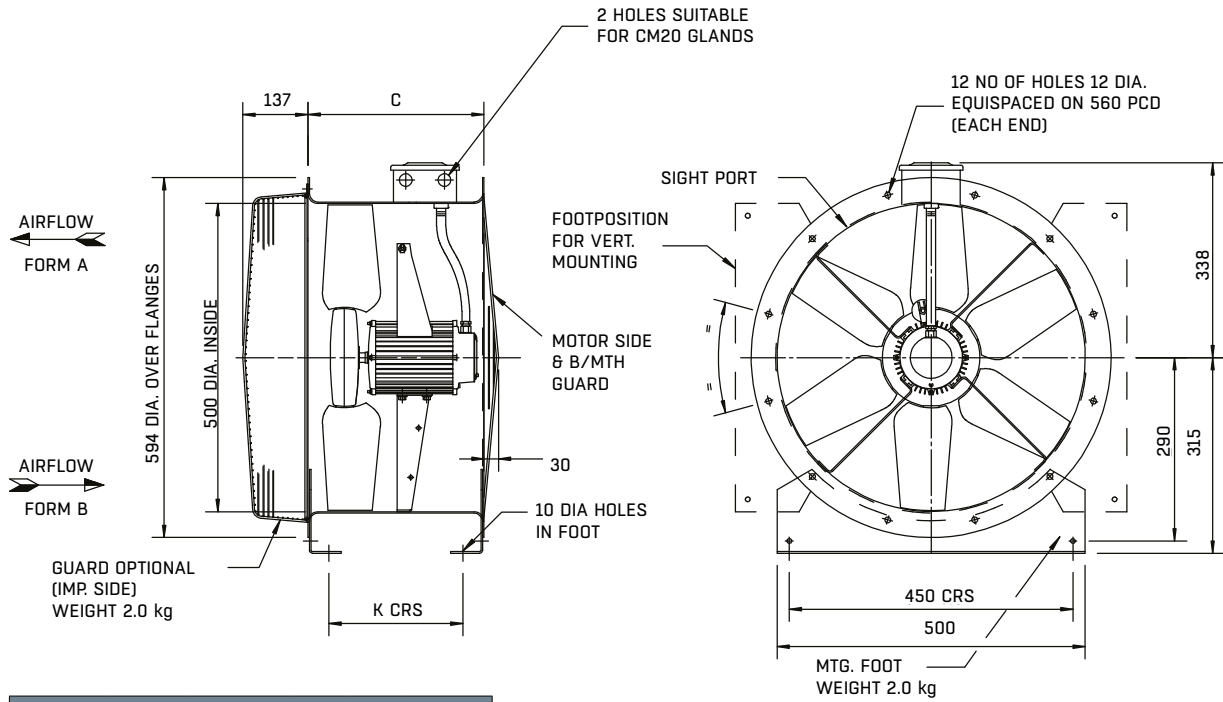

Product Number	Size	Motor Frame	C	K	Weight kg Fan
EJ531274	500	80	375	290	39
EJ531478	500	112M	520	434	76

All dimensions in mm.



JM AEROFOIL PERFORMANCE AND ELECTRICAL DATA

380-420V/50HZ/3 ϕ - L TYPE

PERFORMANCE CHART - 560 MM, 2 POLE

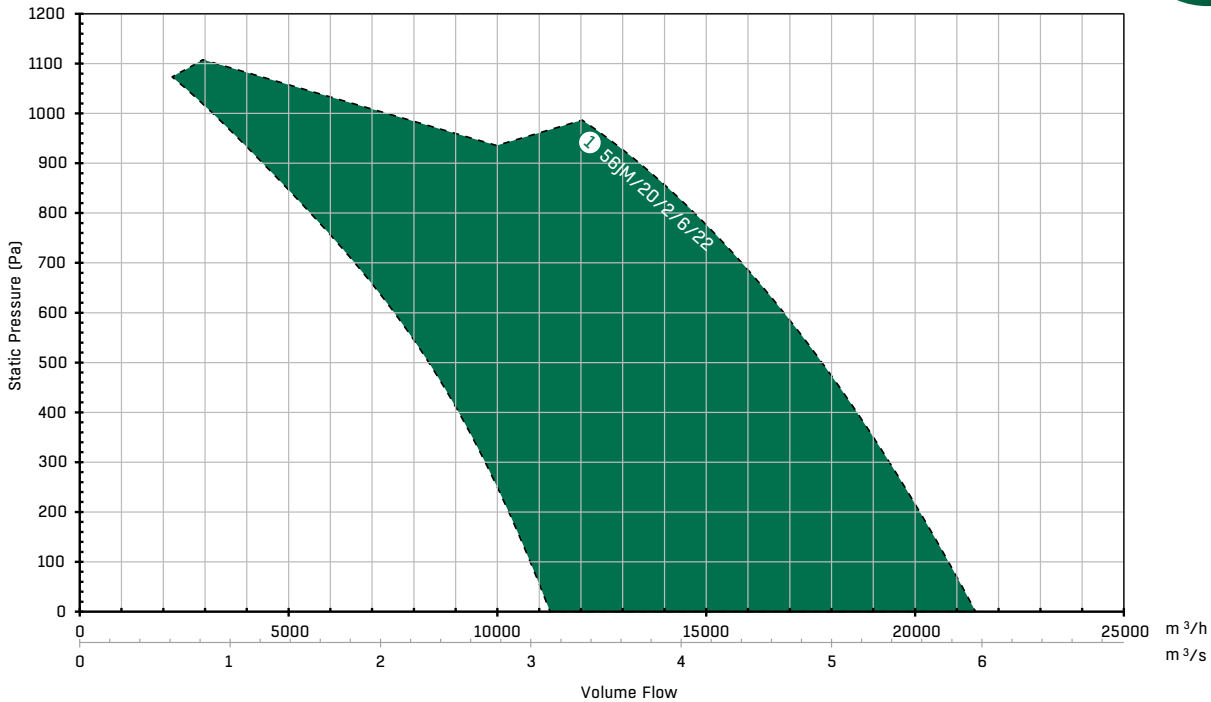

As standard 3 phase JM Aerofoils are supplied at the maximum pitch angle, the envelope curve above illustrates the pitch angle range available on request.

PERFORMANCE TABLE - 560 MM, 2 POLE

Ref	Product Code	m³/s @ Pa (Static)												
		0	50	100	150	200	250	300	400	500	600	700	800	900
1	56JM/20/2/6/22	5.95	5.86	5.77	5.68	5.58	5.48	5.38	5.16	4.93	4.68	4.4	4.08	3.72

PRODUCT AND ELECTRICAL DETAILS - 560 MM, 2 POLE

Ref	Product Code	Product Number	Pitch Angle (°)		Speed rev/min	Motor	Rating (kW)	Full Load Current (A)	Starting Current (A)	Wiring Diagram (CD)	Speed Controller			Sound Levels
			Min	Max							Electronic	Transformer	Inverter	
1	56JM/20/2/6/22	EE591271	8	22	2910	112M (IE2)	6.2	11.7	77.2	CD2417	N/A	N/A	IDDXF54-12	72

For ErP efficiency ratings and grades please refer to our Fan Selector for more information. Sound pressure levels quoted are at the inlet, and are average dBA at 3m distance over a sphere at the mid point at the highest angle given, under free field conditions. These are presented for comparative purposes only. For speed controllers please see pages 250-297.

Non stocked JM Aerofoil are available in 10 working weeks, based on the parts availability. If a reduced lead time is required please contact the office.

Products in **bold** are available from our UK Distributors on next day delivery, if ordered by 4pm. Please call to confirm availability on 01206 222 580.



JM AEROFOIL PERFORMANCE AND ELECTRICAL DATA

380-420V/50HZ/3 ϕ - L TYPE

PERFORMANCE CHART - 560 MM, 4 POLE

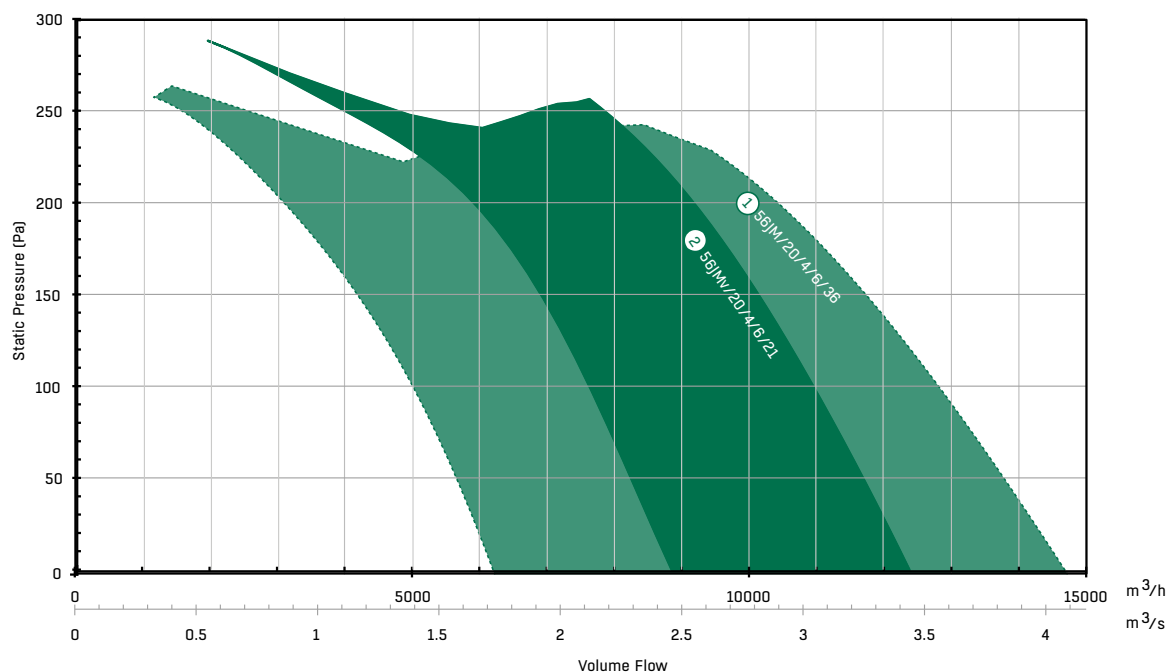

As standard 3 phase JM Aerofoils are supplied at the maximum pitch angle, the envelope curve above illustrates the pitch angle range available on request.

PERFORMANCE TABLE - 560 MM, 4 POLE

Ref	Product Code	m ³ /s @ Pa (Static)					
		0	50	100	150	200	250
1	56JM/20/4/6/36	4.08	3.83	3.56	3.26	2.9	
2	56JMv/20/4/6/21	3.44	3.24	3.03	2.8	2.52	2.15

PRODUCT AND ELECTRICAL DETAILS - 560 MM, 4 POLE

Ref	Product Code	Product Number	Pitch Angle (°)		Speed rev/min	Motor	Rating (kW)	Full Load Current (A)	Starting Current (A)	Wiring Diagram (CD)	Speed Controller			Sound Levels
			Min	Max							Electronic	Transformer	Inverter	
1	56JM/20/4/6/36	EJ591478	10	36	1420	90S (IE2)	1.32	2.84	15.6	CD2416	N/A	N/A	IDDXF54-3.7	62
2	56JMv/20/4/6/21	JV596458	10	21	1400	CT9	1.15	3.2	11	CD3020	N/A	TDID 4A	IDDXF54-3.7	60

For ErP efficiency ratings and grades please refer to our Fan Selector for more information. Sound pressure levels quoted are at the inlet, and are average dBA at 3m distance over a sphere at the mid point at the highest angle given, under free field conditions. These are presented for comparative purposes only. For speed controllers please see pages 250-297.

Non stocked JM Aerofoil are available in 10 working weeks, based on the parts availability. If a reduced lead time is required please contact the office.

Products in **bold** are available from our UK Distributors on next day delivery, if ordered by 4pm. Please call to confirm availability on 01206 222 580.





DRAWINGS - 560 MM

560 MM (EE591271 & EJ591478)

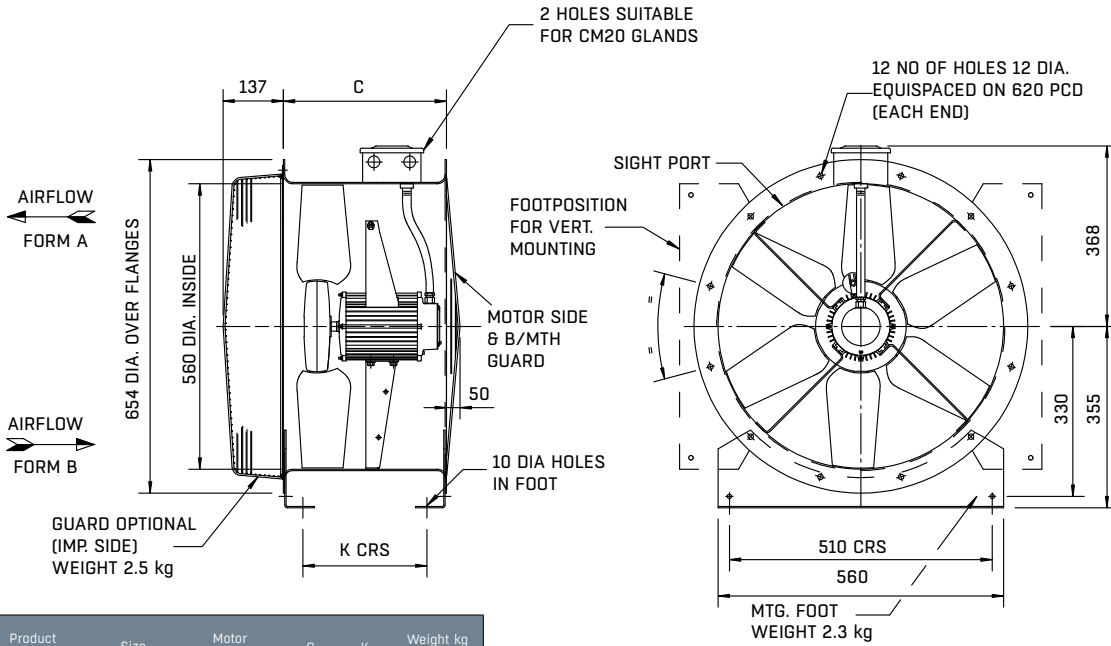

Product Number	Size	Motor Frame	C	K	Weight kg Fan
EJ591478	560	90S	520	434	55
EE591271	560	112M	520	434	78

560 MM (JV596458)

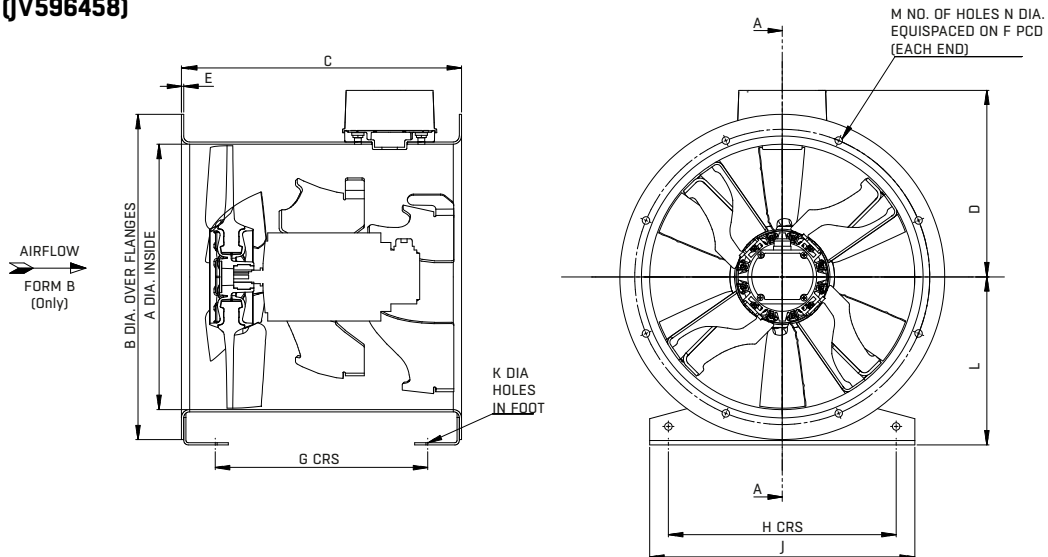

Product Number	Size	Motor frame	A	B	C	D	E	F	G	H	J	K	L	M	N	Weight (KG)
JV596458	560	CT9	560	654	520	352	3	620	420	510	560	10	355	12	12	54

All dimensions in mm.

JM AEROFOIL PERFORMANCE AND ELECTRICAL DATA

380-420V/50HZ/3 ϕ - L TYPE

PERFORMANCE CHART - 630 MM, 2 POLE

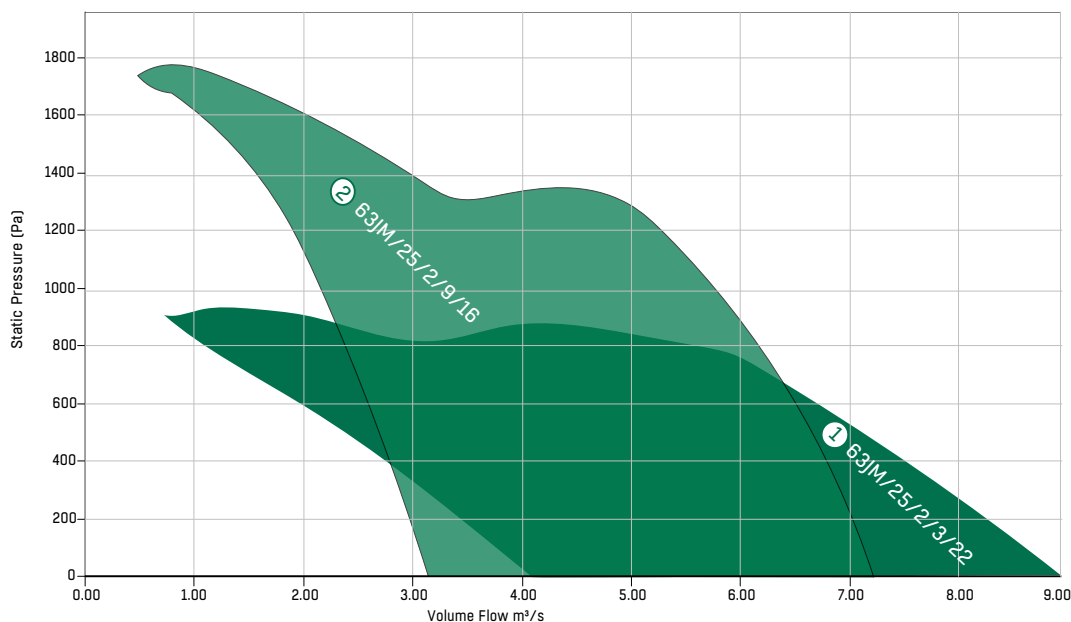

As standard 3 phase JM Aerofoils are supplied at the maximum pitch angle, the envelope curve above illustrates the pitch angle range available on request.

PERFORMANCE TABLE - 630 MM, 2 POLE

Ref	Product Code	m³/s @ Pa (Static)																		
		0	100	200	300	400	500	600	700	800	900	1000	1100	1200	1300	1400	1500	1600	1700	
1	63JM/25/2/3/22	7.31	6.97	6.61	6.24	5.86	5.45	5.02	4.54	3.99										
2	63JM/25/2/9/16	5.56	5.44	5.32	5.2	5.07	4.93	4.79	4.64	4.47	4.3	4.1	3.88	3.62	3.31	2.95	2.51	2.02	1.48	

PRODUCT AND ELECTRICAL DETAILS - 630 MM, 2 POLE

Ref	Product Code	Product Number	Pitch Angle (°)		Speed rev/min	Motor	Rating (kW)	Full Load Current (A)	Starting Current (A)	Wiring Diagram (CD)	Speed Controller			Sound Levels
			Min	Max							Electronic	Transformer	Inverter	
1	63JM/25/2/3/22	EJ661232	8	22	2910	112M	6.2	11.7	77.2	CD2417	N/A	N/A	EA901022	74
2	63JM/25/2/9/16	EJ669201	8	22	2910	160M	13.2	24.6	142.7	CD2417	N/A	N/A	EA901024	77

For ErP efficiency ratings and grades please refer to our Fan Selector for more information. Sound pressure levels quoted are at the inlet, and are average dBA at 3m distance over a sphere at the mid point at the highest angle given, under free field conditions. These are presented for comparative purposes only. For speed controllers please see pages 250-297.

Non stocked JM Aerofoil are available in 10 working weeks, based on the parts availability. If a reduced lead time is required please contact the office.

Products in **bold** are available from our UK Distributors on next day delivery, if ordered by 4pm. Please call to confirm availability on 01206 222 580.





JM AEROFOIL PERFORMANCE AND ELECTRICAL DATA

380-420V/50HZ/3 ϕ - L TYPE

PERFORMANCE CHART - 630 MM, 4 POLE

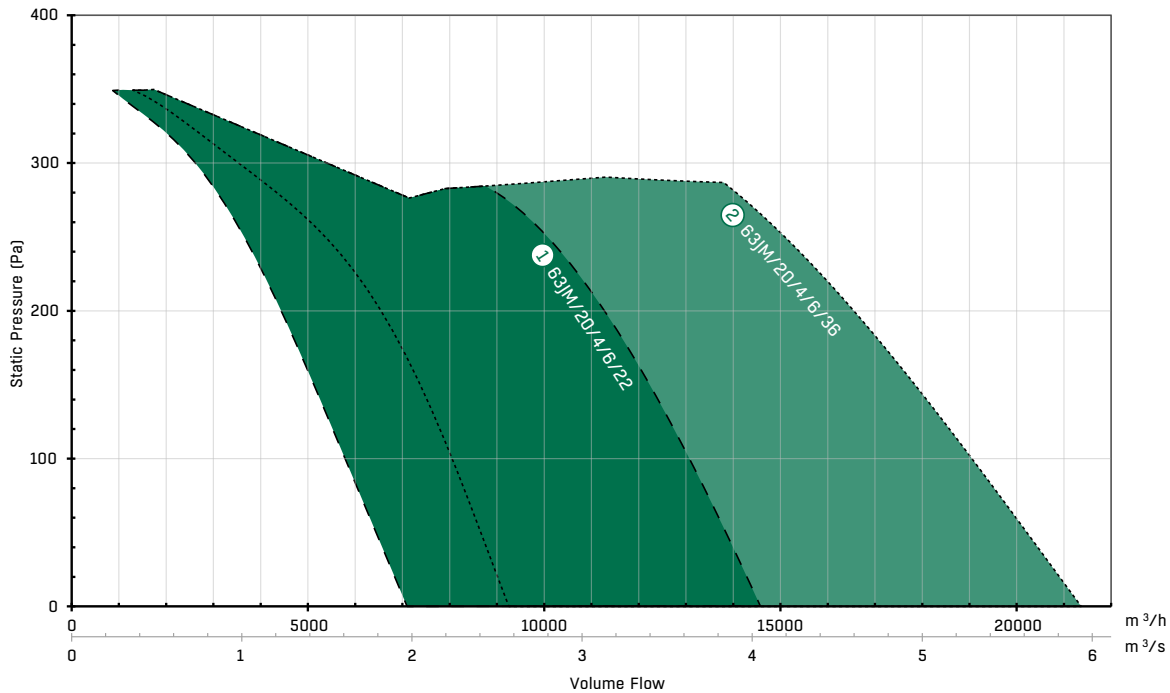

As standard 3 phase JM Aerofoils are supplied at the maximum pitch angle, the envelope curve above illustrates the pitch angle range available on request.

PERFORMANCE TABLE - 630 MM, 4 POLE

Ref	Product Code	m³/s @ Pa (Static)					
		0	50	100	150	200	250
1	63JM/20/4/6/22	4.04	3.84	3.63	3.39	3.13	2.79
2	63JM/20/4/6/36	5.93	5.61	5.29	4.95	4.59	4.19

PRODUCT AND ELECTRICAL DETAILS - 630 MM, 4 POLE

Ref	Product Code	Product Number	Pitch Angle (°)		Speed rev/min	Motor	Rating (kW)	Full Load Current (A)	Starting Current (A)	Wiring Diagram (CD)	Speed Controller			Sound Levels
			Min	Max							Electronic	Transformer	Inverter	
1	63JM/20/4/6/22	EE661473	8	22	1420	90S (IE2)	1.32	2.84	15.6	CD2416	N/A	N/A	IDDXF54-3.7	60
2	63JM/20/4/6/36	EJ661474	12	36	1420	100L (IE2)	2.64	5.49	30.74	CD2416	N/A	N/A	IDDXF54-7.2	64

For ErP efficiency ratings and grades please refer to our Fan Selector for more information. Sound pressure levels quoted are at the inlet, and are average dBA at 3m distance over a sphere at the mid point at the highest angle given, under free field conditions. These are presented for comparative purposes only. For speed controllers please see pages 250-297.

Non stocked JM Aerofoil are available in 10 working weeks, based on the parts availability. If a reduced lead time is required please contact the office.

Products in **bold** are available from our UK Distributors on next day delivery, if ordered by 4pm. Please call to confirm availability on 01206 222 580.



DRAWINGS - 630 MM

630 MM (EE661473 & EJ661474)

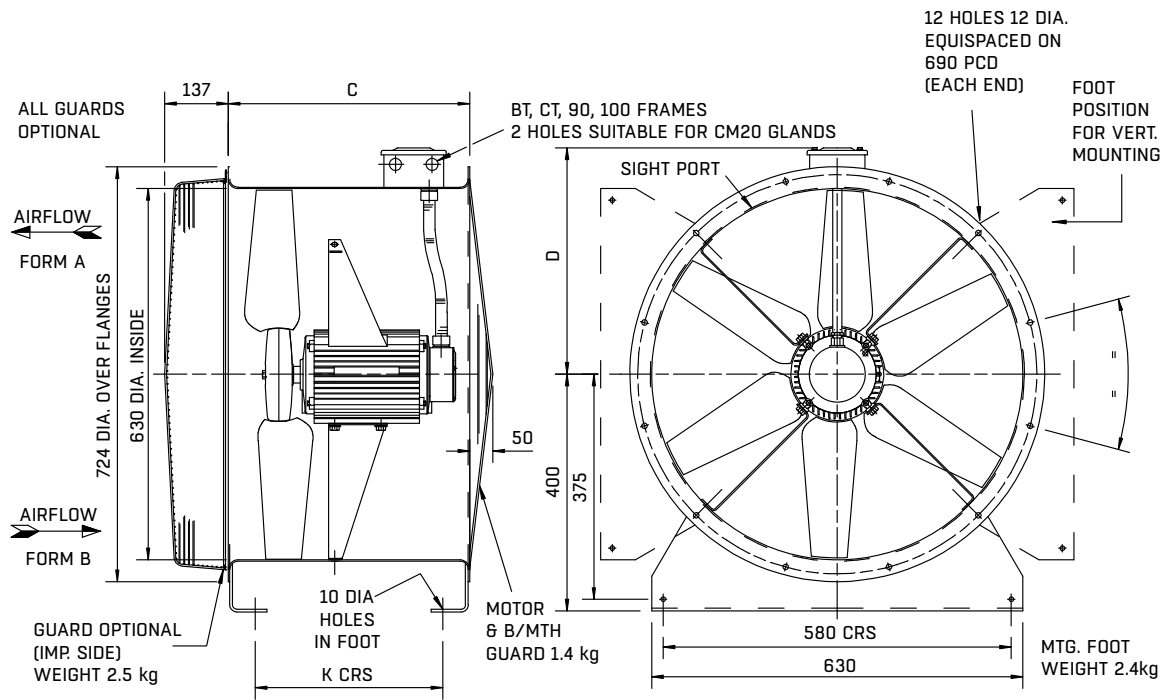

Product Number	Size	Motor Frame	C	D	K	Weight kg Fan
EE661473	630	90S	520	403	434	61
EJ661474	630	100L	520	403	434	80
EJ661232	630	112M	520	403	434	92
EJ669201	630	160M	625	440	619	202

All dimensions in mm.



JM AEROFOIL PERFORMANCE AND ELECTRICAL DATA

380-420V/50HZ/3 ϕ - L TYPE

PERFORMANCE CHART - 710 MM, 4 POLE

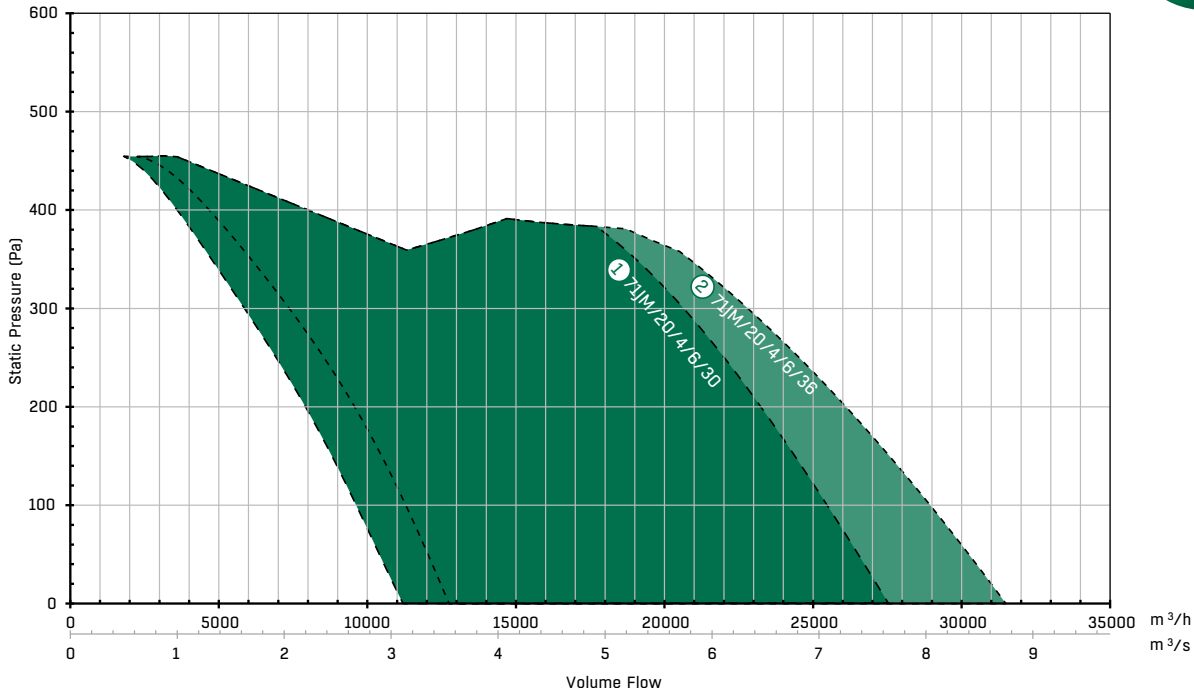

As standard 3 phase JM Aerofoils are supplied at the maximum pitch angle, the envelope curve above illustrates the pitch angle range available on request.

PERFORMANCE TABLE - 710 MM, 4 POLE

Ref	Product Code	m³/s @ Pa (Static)						
		0	50	100	150	200	250	300
1	71JM/20/4/6/30	7.64	7.36	7.07	6.77	6.45	6.11	5.73
2	71JM/20/4/6/36	8.74	8.4	8.03	7.65	7.25	6.81	6.33

PRODUCT AND ELECTRICAL DETAILS - 710 MM, 4 POLE

Ref	Product Code	Product Number	Pitch Angle (°)		Speed rev/min	Motor	Rating (kW)	Full Load Current (A)	Starting Current (A)	Wiring Diagram (CD)	Speed Controller			Sound Levels
			Min	Max							Electronic	Transformer	Inverter	
1	71JM/20/4/6/30	EE741471	8	30	1440	100L (IE2)	3.6	7.29	40.09	CD2416	N/A	N/A	IDDXF54-9	67
2	71JM/20/4/6/36	EJ741474	10	36	1440	112M (IE2)	4.8	9.7	49.4	CD2417	N/A	N/A	IDDXF54-9	69

For ErP efficiency ratings and grades please refer to our Fan Selector for more information. Sound pressure levels quoted are at the inlet, and are average dBA at 3m distance over a sphere at the mid point at the highest angle given, under free field conditions. These are presented for comparative purposes only. For speed controllers please see pages 250-297.

Non stocked JM Aerofoil are available in 10 working weeks, based on the parts availability. If a reduced lead time is required please contact the office.

Products in **bold** are available from our UK Distributors on next day delivery, if ordered by 4pm. Please call to confirm availability on 01206 222 580.



DRAWINGS - 710 MM

710 MM (EE741471 & EJ741474)

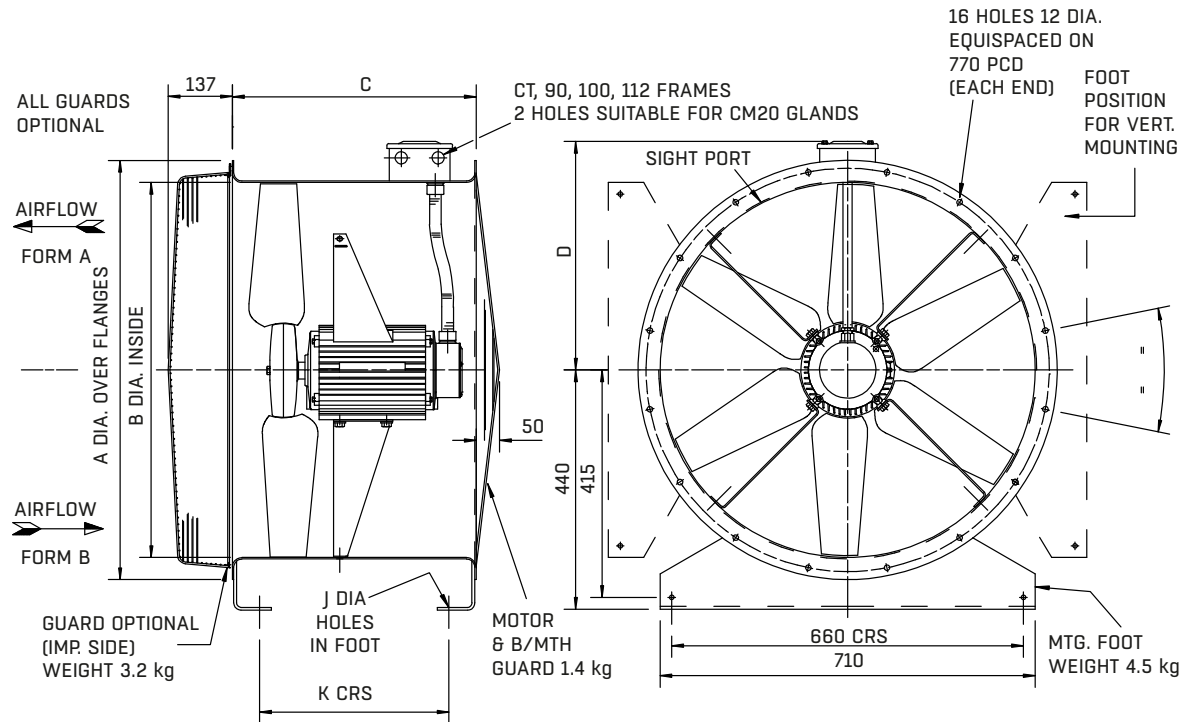

Product Number	Size	Motor Frame	A	B	C	D	J	K	Weight kg Fan
EE741471	710	100L	804	710	520	443	10	434	84
EJ741474	710	112M	804	710	520	443	10	434	95

All dimensions in mm.



JM AEROFOIL PERFORMANCE AND ELECTRICAL DATA

380-420V/50HZ/3 ϕ - L TYPE

PERFORMANCE CHART - 800 MM, 4 POLE

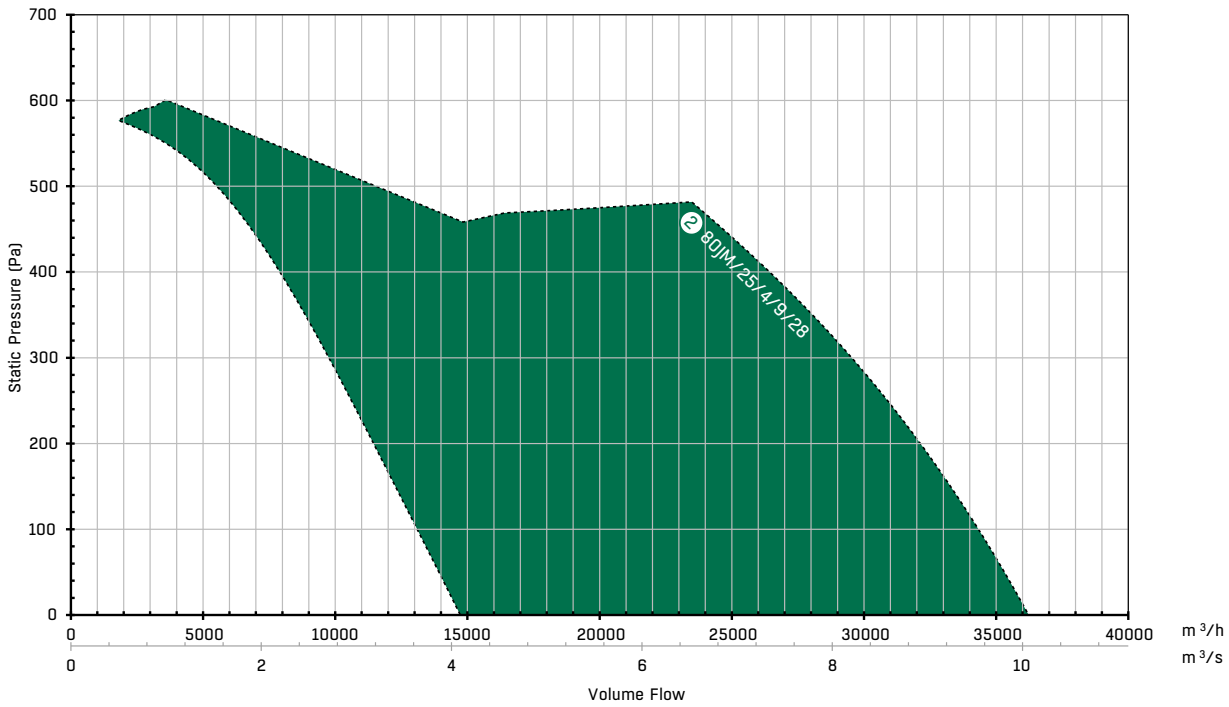

As standard 3 phase JM Aerofoils are supplied at the maximum pitch angle, the envelope curve above illustrates the pitch angle range available on request.

PERFORMANCE TABLE - 800 MM, 4 POLE

Ref	Product Code	m³/s @ Pa (Static)							
		0	50	100	150	200	250	300	400
1	80JM/25/4/9/28	10.06	9.8	9.53	9.24	8.92	8.58	8.2	7.34

PRODUCT AND ELECTRICAL DETAILS - 800 MM, 4 POLE

Ref	Product Code	Product Number	Pitch Angle (°)		Speed rev/min	Motor	Rating (kW)	Full Load Current (A)	Starting Current (A)	Wiring Diagram (CD)	Speed Controller			Sound Levels
			Min	Max							Electronic	Transformer	Inverter	
1	80JM/25/4/9/28	EE831478	8	28	1455	132S (IE2)	6.33	12.6	76.25	CD2417	N/A	N/A	IDDXF54-15.5	71

For ErP efficiency ratings and grades please refer to our Fan Selector for more information. Sound pressure levels quoted are at the inlet, and are average dBA at 3m distance over a sphere at the mid point at the highest angle given, under free field conditions. These are presented for comparative purposes only. For speed controllers please see pages 250-297.

Non stocked JM Aerofoil are available in 10 working weeks, based on the parts availability. If a reduced lead time is required please contact the office.

Products in **bold** are available from our UK Distributors on next day delivery, if ordered by 4pm. Please call to confirm availability on 01206 222 580.



DRAWINGS - 800 MM

800 MM (EE831478)

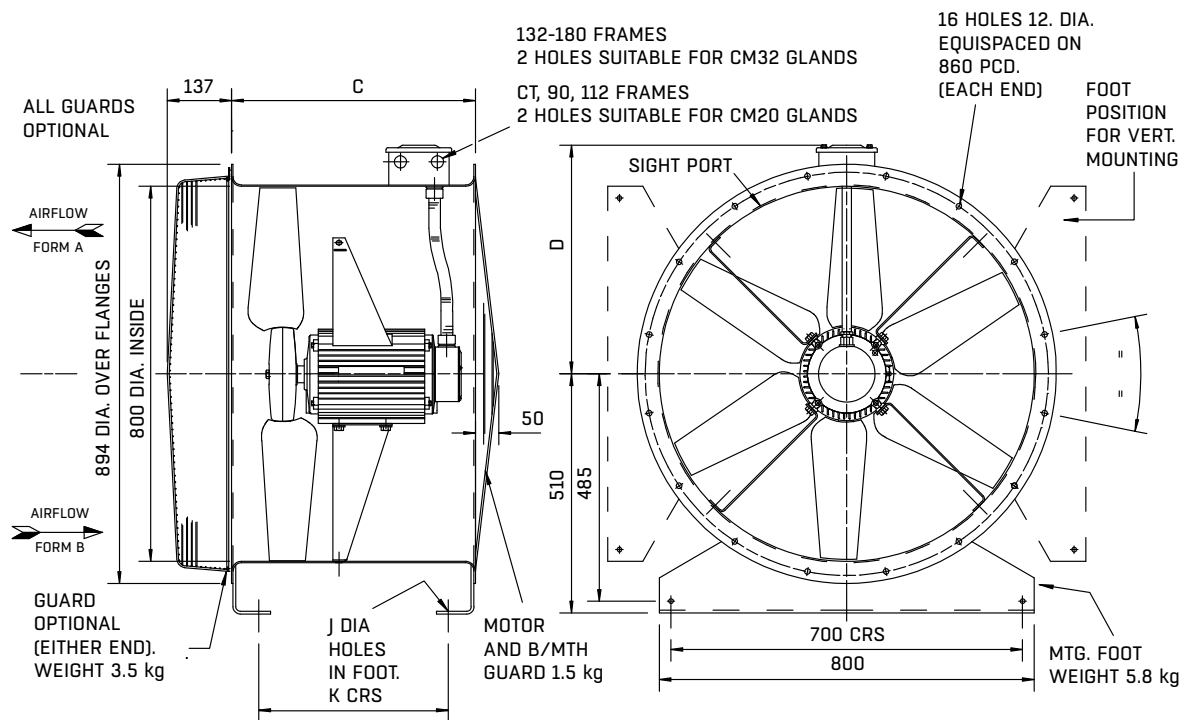

Product Number	Size	Motor Frame	C	D	J	K	Weight kg Fan
EE831478	800	132S	520	480	12	434	166

All dimensions in mm.



JM AEROFOIL PERFORMANCE AND ELECTRICAL DATA

380-420V/50HZ/3 ϕ - L TYPE

PERFORMANCE CHART - 900 MM, 4 POLE

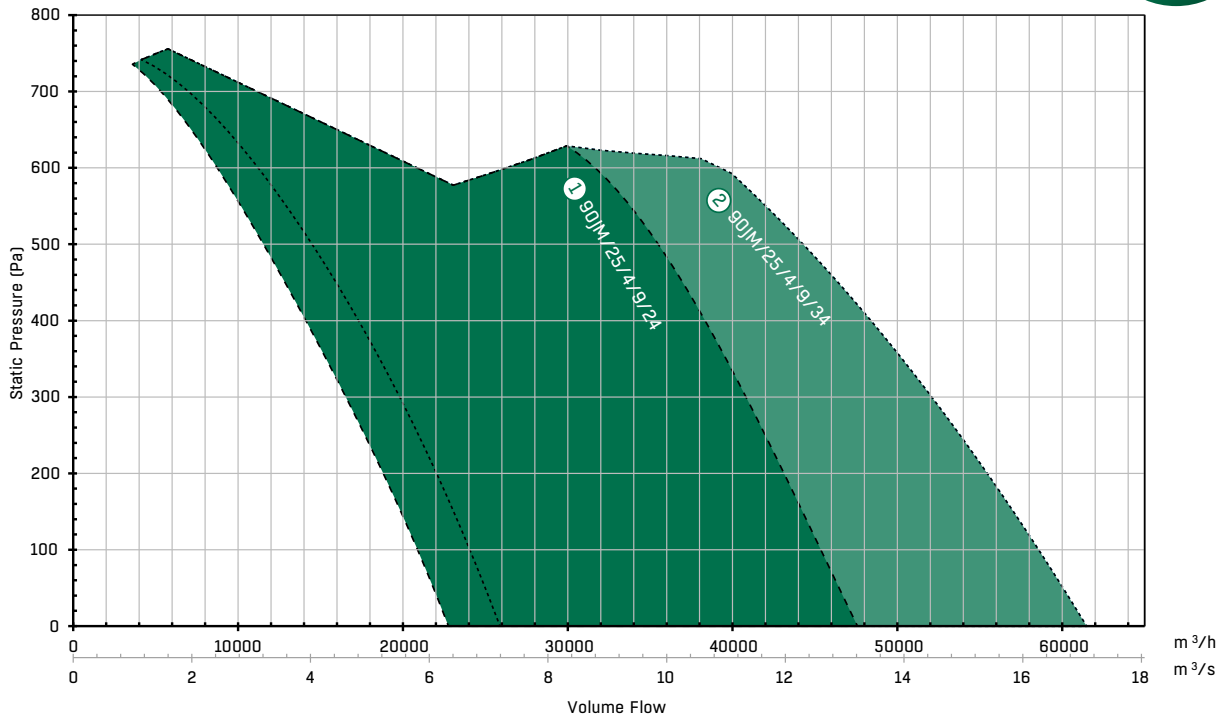

As standard 3 phase JM Aerofoils are supplied at the maximum pitch angle, the envelope curve above illustrates the pitch angle range available on request.

PERFORMANCE TABLE - 900 MM, 4 POLE

Ref	Product Code	m ³ /s @ Pa (Static)									
		0	50	100	150	200	250	300	400	500	600
1	90JM/25/4/9/24	13.21	12.9	12.6	12.29	11.97	11.65	11.33	10.64	9.85	8.79
2	90JM/25/4/9/34	17.07	16.67	16.26	15.84	15.4	14.94	14.46	13.44	12.29	

PRODUCT AND ELECTRICAL DETAILS - 900 MM, 4 POLE

Ref	Product Code	Product Number	Pitch Angle (°)		Speed rev/min	Motor	Rating (kW)	Full Load Current (A)	Starting Current (A)	Wiring Diagram (CD)	Speed Controller			Sound Levels
			Min	Max							Electronic	Transformer	Inverter	
1	90JM/25/4/9/24	EE931473	8	24	1440	132M (IE2)	9	17.1	100.89	CD2417	N/A	N/A	IDDXF54-23	75
2	90JM/25/4/9/34	EJ931476	10	34	1440	160M (IE2)	13.2	25.3	135.7	CD2417	N/A	N/A	IDDXF54-31	77

For ErP efficiency ratings and grades please refer to our Fan Selector for more information. Sound pressure levels quoted are at the inlet, and are average dBA at 3m distance over a sphere at the mid point at the highest angle given, under free field conditions. These are presented for comparative purposes only. For speed controllers please see pages 250-297.

Non stocked JM Aerofoil are available in 10 working weeks, based on the parts availability. If a reduced lead time is required please contact the office.

Products in **bold** are available from our UK Distributors on next day delivery, if ordered by 4pm. Please call to confirm availability on 01206 222 580.



DRAWINGS - 900 MM

900 MM (EE931473 & EJ931476)

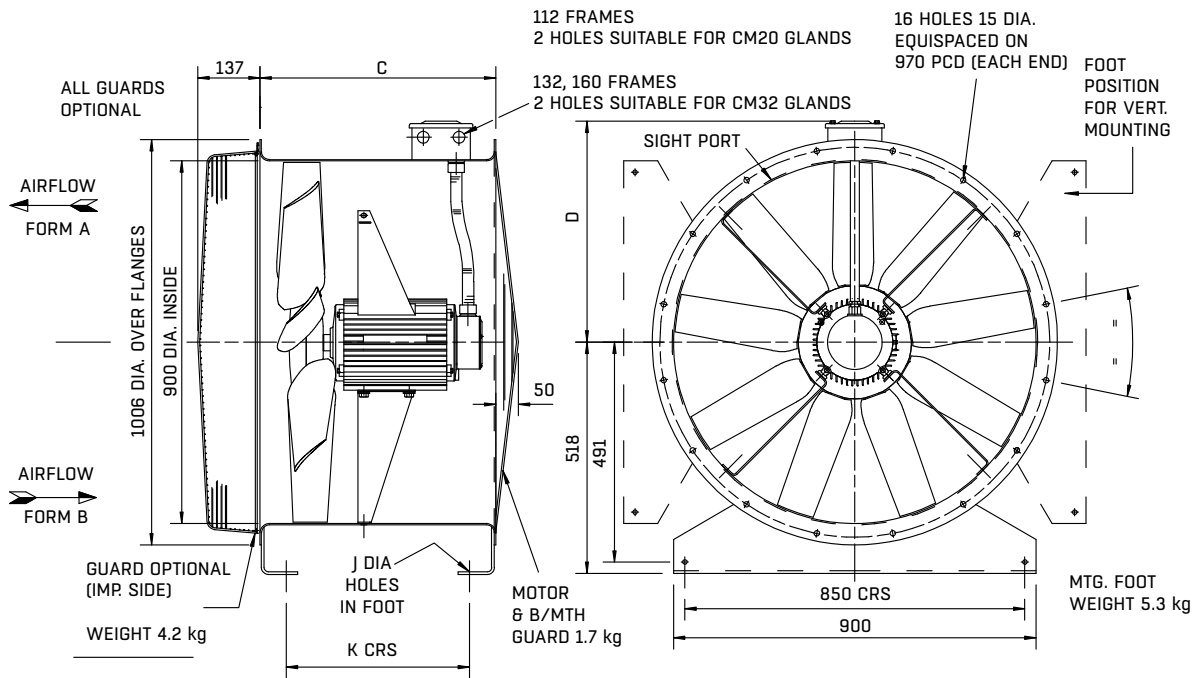

Product Number	Size	Motor Frame	C	D	J	K	Weight kg Fan
EE931473	900	132M	520	575	12	440	179
EJ931476	900	160M	625	575	12	545	248

All dimensions in mm.



JM AEROFOIL PERFORMANCE AND ELECTRICAL DATA

380-420V/50HZ/3 ϕ - L TYPE

PERFORMANCE CHART - 1000 MM, 4 POLE

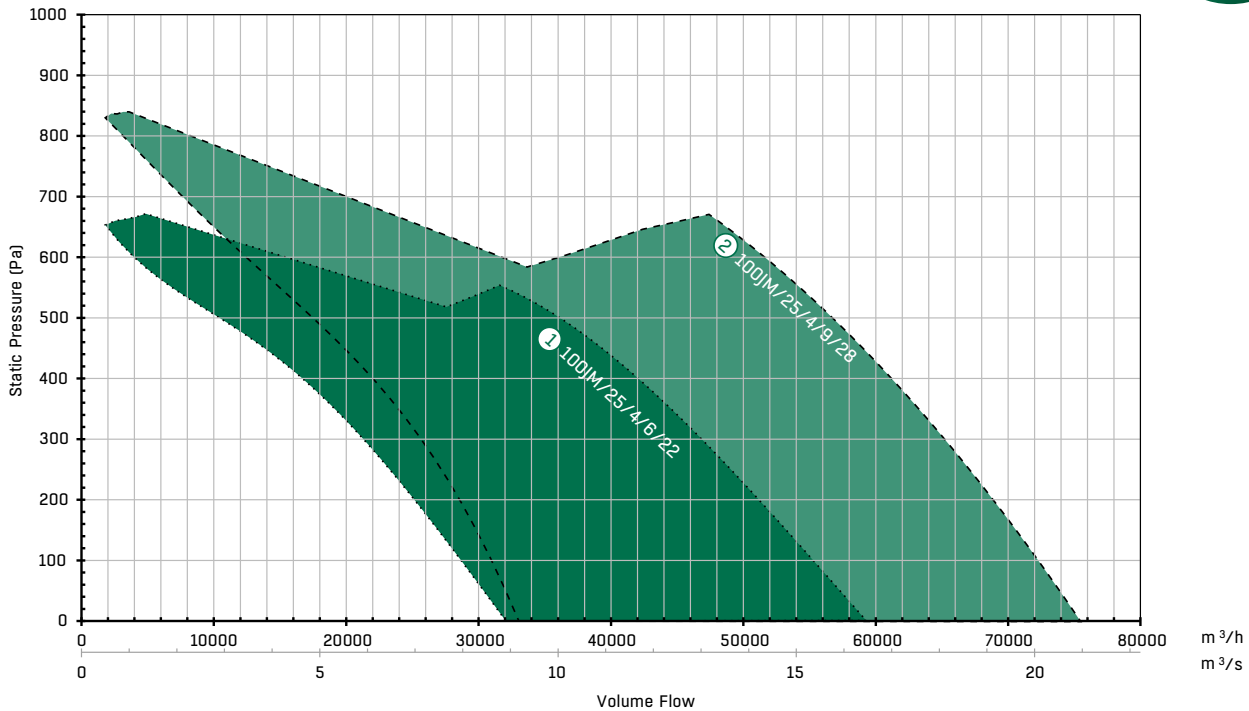

As standard 3 phase JM Aerofoils are supplied at the maximum pitch angle, the envelope curve above illustrates the pitch angle range available on request.

PERFORMANCE TABLE - 1000 MM, 4 POLE

Ref	Product Code	m ³ /s @ Pa (Static)									
		0	50	100	150	200	250	300	400	500	600
1	100JM/25/4/6/22	16.46	15.91	15.35	14.78	14.21	13.62	13.01	11.68	10.04	
2	100JM/25/4/9/28	20.96	20.52	20.07	19.61	19.12	18.63	18.11	16.99	15.75	14.33

PRODUCT AND ELECTRICAL DETAILS - 1000 MM, 4 POLE

Ref	Product Code	Product Number	Pitch Angle (°)		Speed rev/min	Motor	Rating (kW)	Full Load Current (A)	Starting Current (A)	Wiring Diagram (CD)	Speed Controller			Sound Levels
			Min	Max							Electronic	Transformer	Inverter	
1	100JM/25/4/6/22	EE133472	8	22	1440	132M (IE2)	9	17.1	100.89	CD2417	N/A	N/A	IDDXF54-23	79
2	100JM/25/4/9/28	EE131475	8	28	1470	160L (IE2)	18	34.2	177.81	CD2417	N/A	N/A	IDDXF54-37	81

Sound pressure levels quoted are at the inlet, and are average dBA at 3m distance over a sphere at the mid point at the highest angle given, under free field For ErP efficiency ratings and grades please refer to our Fan Selector for more information. These are presented for comparative purposes only. For speed controllers please see pages 250-297.

Non stocked JM Aerofoil are available in 10 working weeks, based on the parts availability. If a reduced lead time is required please contact the office.

Products in **bold** are available from our UK Distributors on next day delivery, if ordered by 4pm. Please call to confirm availability on 01206 222 580.



DRAWINGS 1000 MM

1000 MM (EE133472 & EE131475)

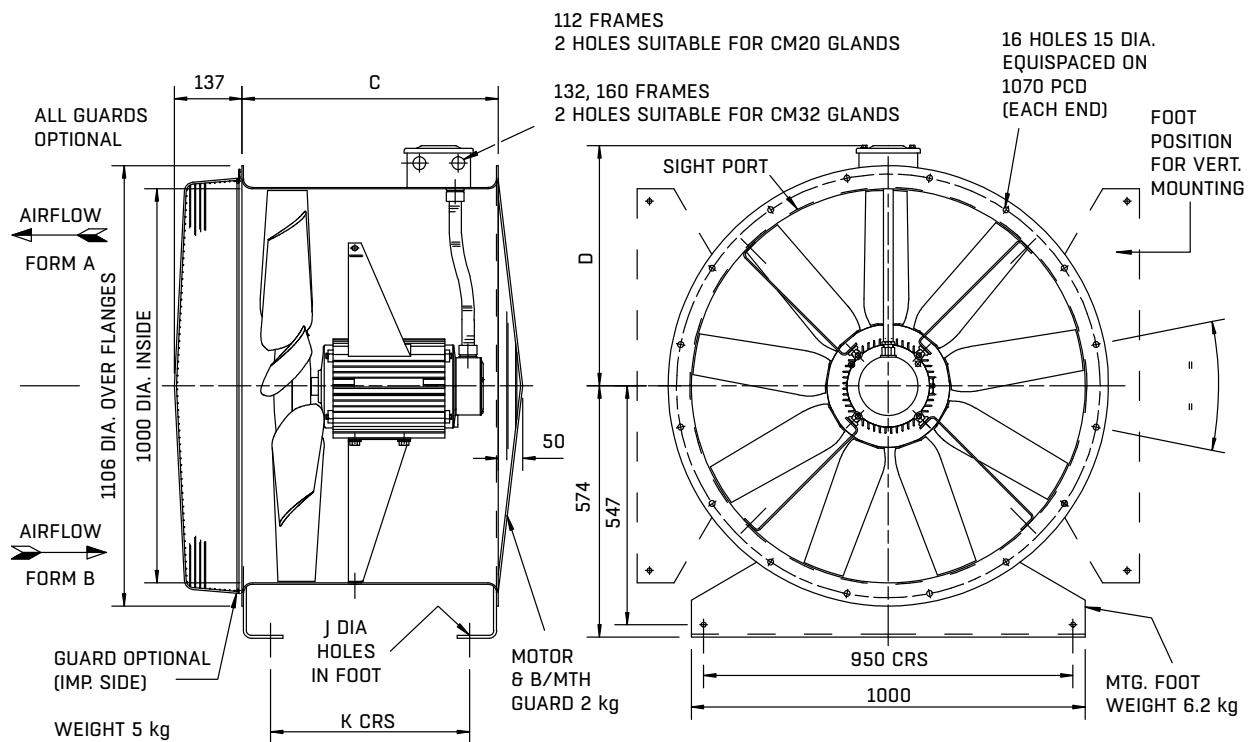

Product Number	Size	Motor Frame	C	D	J	K	Weight kg Fan
EE133472	1000	132M	520	625	12	440	218
EE131475	1000	160L	711	625	12	629	295

All dimensions in mm.



WIRING DIAGRAMS - JM AEROFOIL

CD2416

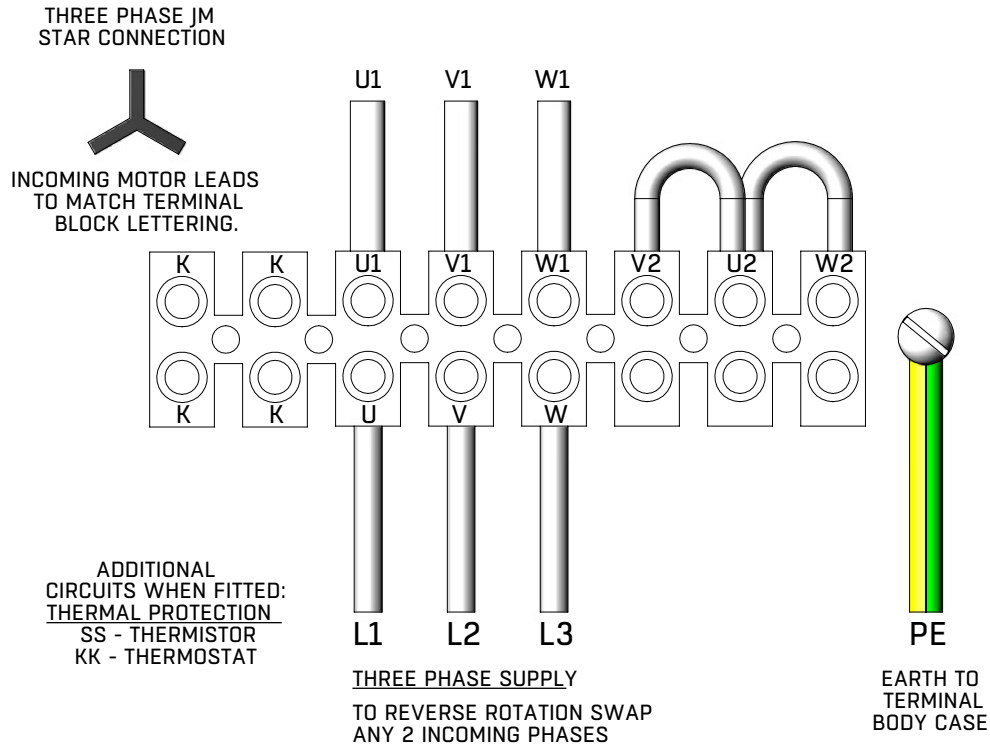

CD2417

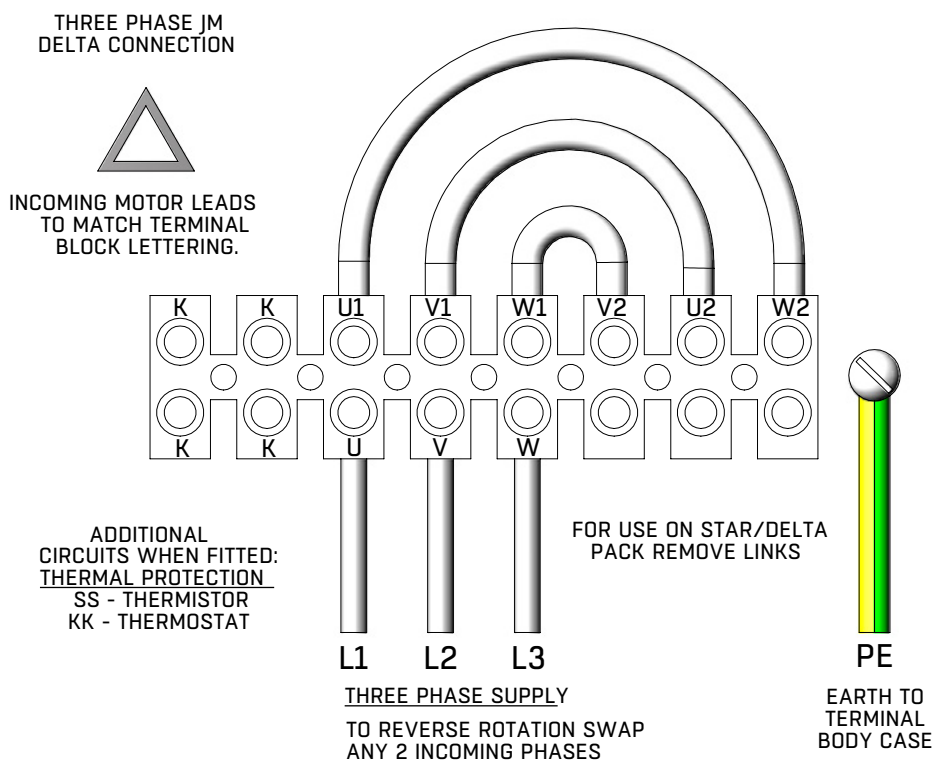

WIRING DIAGRAMS - JMv AEROFOIL

CD3018

CONNECTION DIAGRAM FOR THREE PHASE DUAL VOLTAGE, STAR
ACDE ROTATION

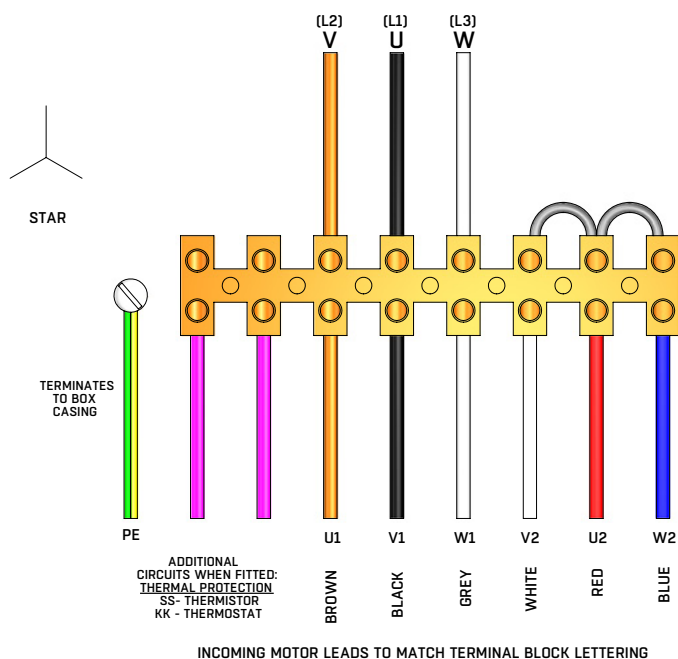

CD3020

CONNECTION DIAGRAM FOR THREE PHASE DELTA FIXED SPEED
ACDE ROTATION

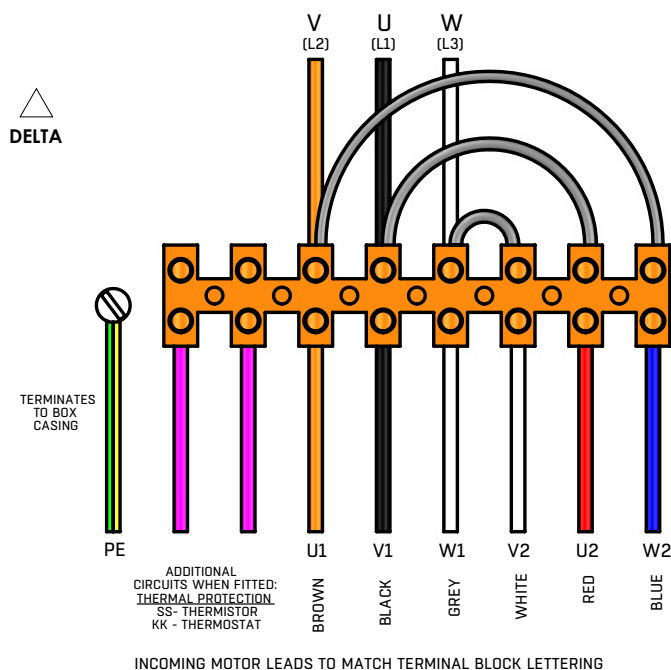



WIRING DIAGRAMS - JM AEROFOIL

CD3033 - JM 1 PHASE (CONNECTED TEID 1A)

JM CONNECTED TO TEID 1A TRANSFORMER SPEED CONTROLLER

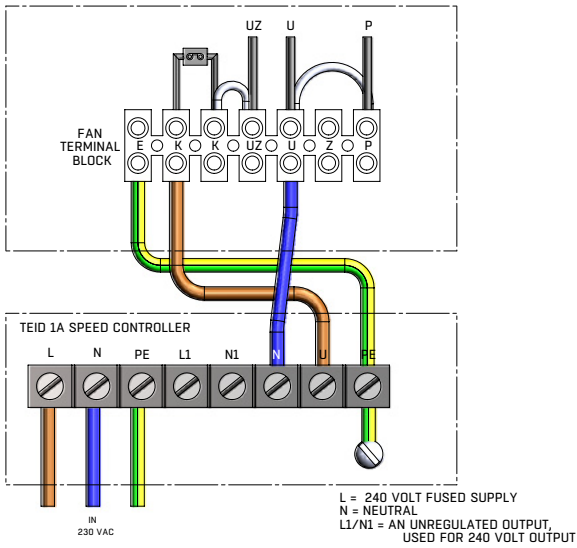

CD3035 - JM 1 PHASE (CONNECTED TEID 1.5-2.2A)

JM CONNECTED TO TEID 1.5-2.2A TRANSFORMER SPEED CONTROLLER

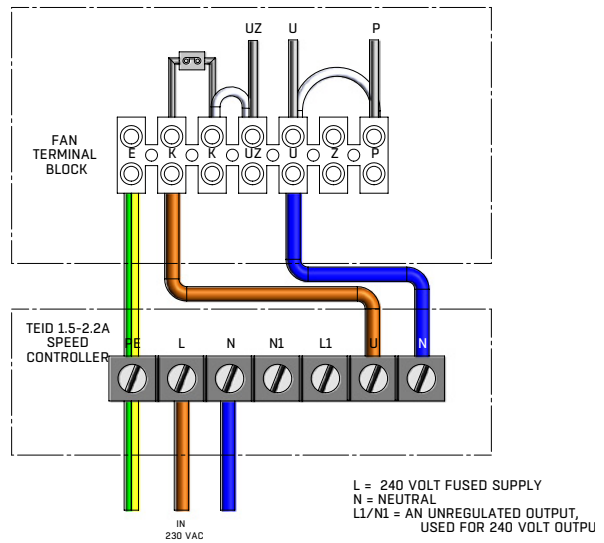

CD3034 - JM 1 PHASE (CONNECTED TEID 3.5-5.5A)

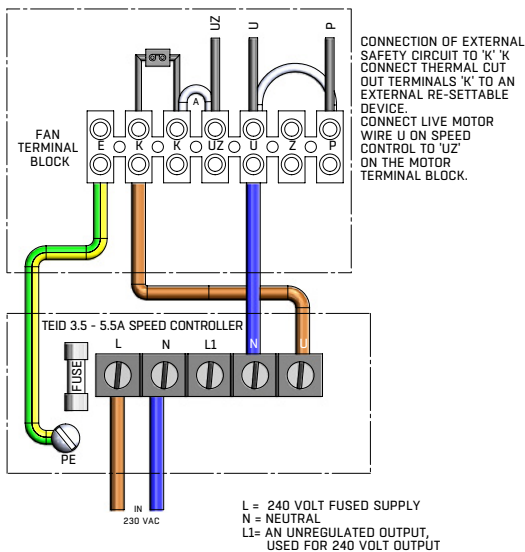

CD3034 - JM 1 PHASE (CONNECTED TEID 7.5-13A)

