



Incorporating



V2.1



***Product spec >>>***

**> Series NV - Non vision grilles**

# Grilles

## Non-vision

Recommended for:

Wall & door

Supply & extract

### Overview

#### *Block line of sight into private areas*

Giving adequate ventilation in areas where privacy must be maintained can be a challenge. NV1-3 non vision grilles have a special chevron blade arrangement, completely blocking line of sight through the grille.

<b>Free area (NV1, NV2, NV4):</b>	Approx 38%
<b>Free area (NV3):</b>	Approx 15%
<b>Mass/M sq face area (NV1):</b>	12.5 kg
<b>Mass/M sq face area (NV2):</b>	15 kg
<b>Mass/M sq face area (NV3):</b>	23 kg
<b>Mass/M sq face area (NV4):</b>	11 kg

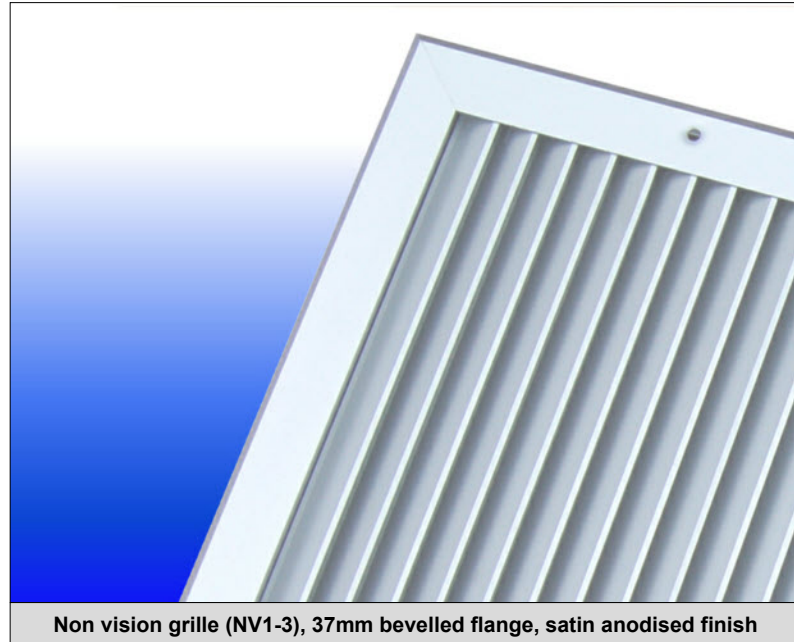

### Specifications:

<b>Materials:</b>	Extruded aluminium throughout.
<b>Construction:</b>	Frame held together using punched in steel corners. Core held in by frame design.
<b>Frame:</b>	NV1/2/3 - 37mm bevelled. NV4 - Slimline surface mounted. Optional - Core only.
<b>Fixings:</b>	Standard (NV1, NV2 & NV3) - None. Standard (NV4) - Countersunk face fixing holes.
<b>Sizes:</b>	Minimum size single unit 100mm x 100mm. Maximum size single unit 2900mm x 2900mm.
<b>Finish:</b>	Standard - Satin anodised (AA5). Optional - Polyester powder coat to any RAL / BS colour.

### Sight blocking

The special chevron blade shape used on NV1, NV2 and NV3 grilles allows blades to interlock, completely blocking line of sight from any angle. NV4 grilles utilise a different, non chevron blade needed for the slimline construction. As a result a very narrow line of sight can be obtained by looking up at the grille from directly below.

### Aesthetics

Form however is just as important as function, and NV grilles have been designed to look as good as possible. NV1 - 3 grilles use the same style frames as the wider range of HVC grilles, for continuity across a range of grille types.

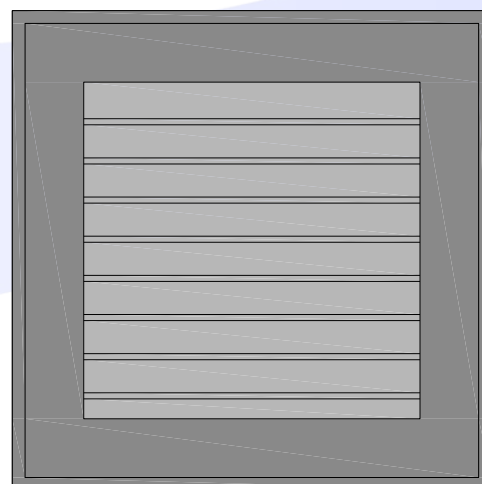

### Models

**NV1** - Standard grille.

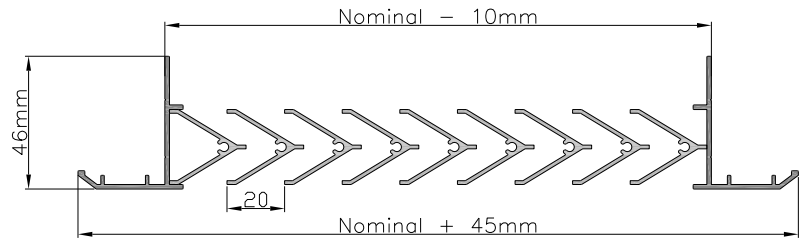

**NV2** - As NV1 with telescopic backing frame.

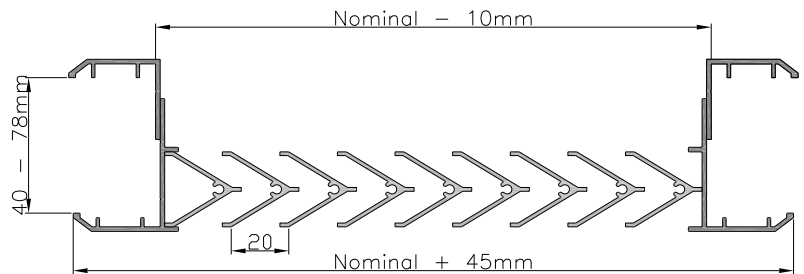

**NV3** - Double layered, intended for darkrooms.

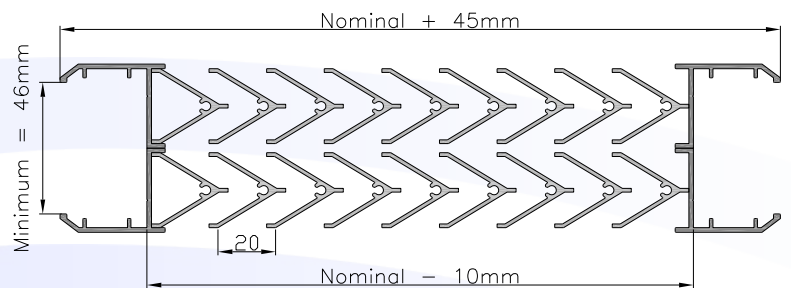

**NV4** - Surface mounted, for use in fire doors, where they can be used with intumescent fire blocks or NCA S300 fire dampers. Please note NV4 grilles do not incorporate a chevron blade and hence do not block line of sight from all angles.

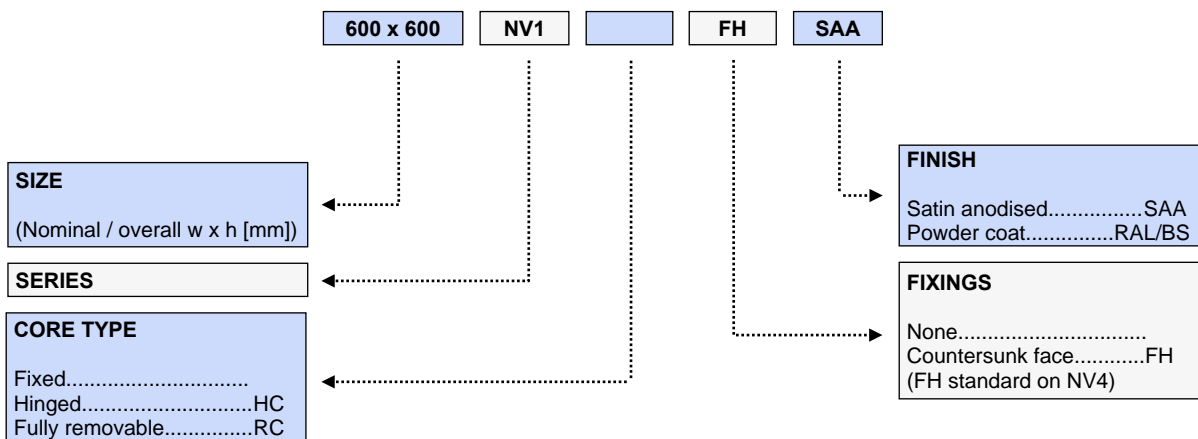
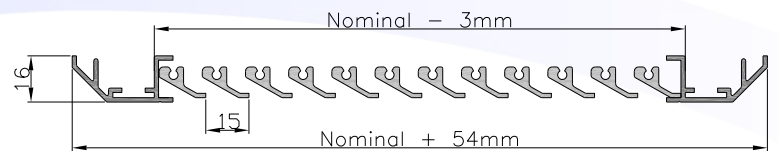

# Grilles

## Hinged & removable cores

### Overview

Envisage you need access to the ductwork behind a grille to inspect a fire damper, or to adjust a rear mounted opposed blade damper.

Without a removable or hinged core the whole grille will have to be removed. Not only a time consuming process, but also likely damaging the grille itself and the wall or ceiling in the process.

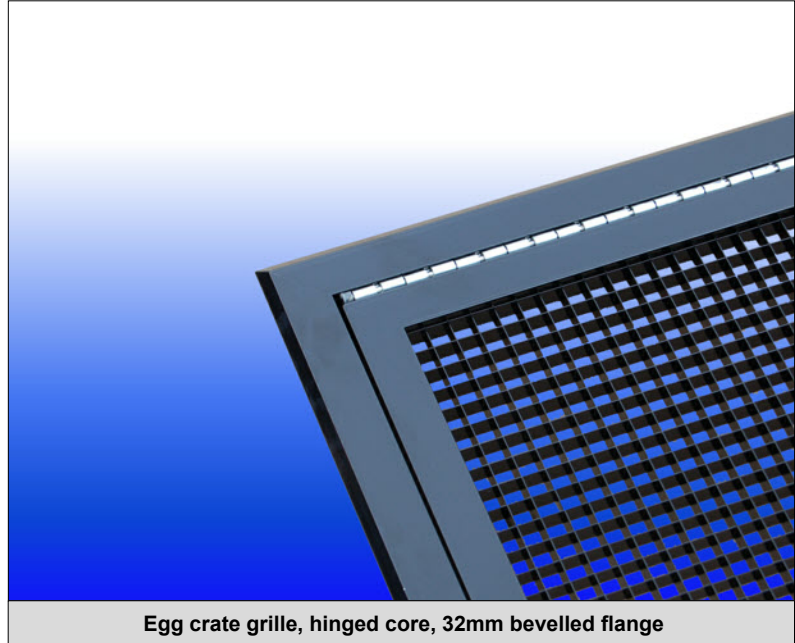

Egg crate grille, hinged core, 32mm bevelled flange

### Removable core

Enabling the core to be removed entirely from the frame allows maximum entry space into ductwork behind.

Held within its own frame, the core comes out in one whole unit for maximum ease.

Colour matched bolts are fitted as standard.

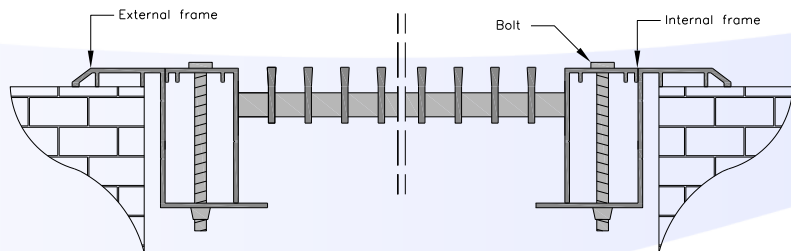

### Hinged core

Held within its own frame as with the removable option, a silver piano hinge is fitted to one side of the internal frame.

Able to swing out to 180°, access through hinged grilles is comparable to their fully removable cousins.

Cam fasteners are fitted as standard, bolts will be fitted upon specification.

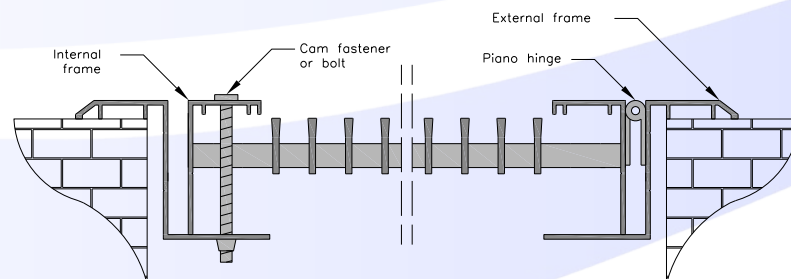

Core type	Grille series													
	SD	DD	FB	ECG	NV	CB	LG	LGFR	CFLG	RGS	PSG	LFP	PPG	LCD
Hinged core	✓	✓	✓	✓	✓	✓	✓	✗	N/A	N/A	N/A	✓	✓	✓
Removable core	✓	✓	✓	✓	✓	✓	✓	✗				✓	✓	✓

# Grilles

## Fitting options

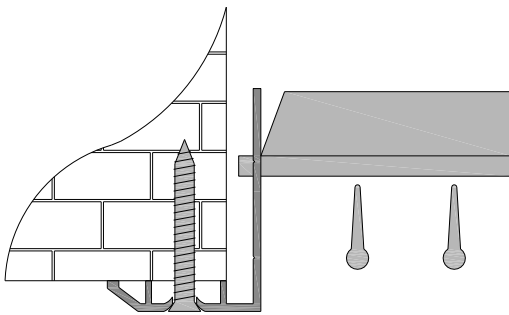

### Countersunk fixing holes: Code suffix FH

Countersunk fixing holes in the grille frame are the easiest fitting method. Screws in the same finish are supplied with the grille.

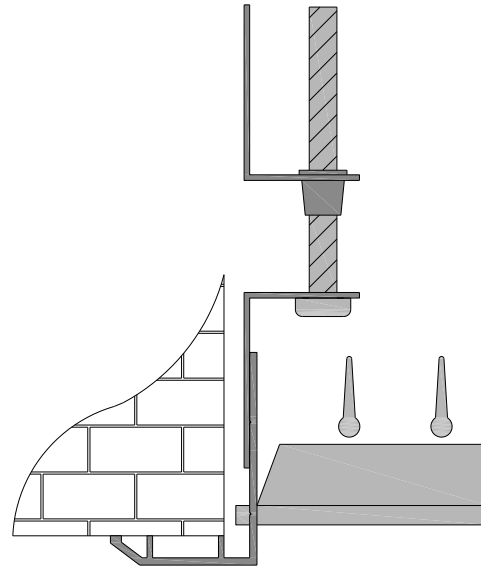

### Concealed fixings: Code suffix CF

Consisting of L brackets with threaded ports, one L bracket is fixed into the ductwork or plenum, the other is riveted to the rear of the grille frame. Supplied bolts are then used to hold the grille into the supporting structure.

Not suitable for NV grilles unless removable / hinged core specified.

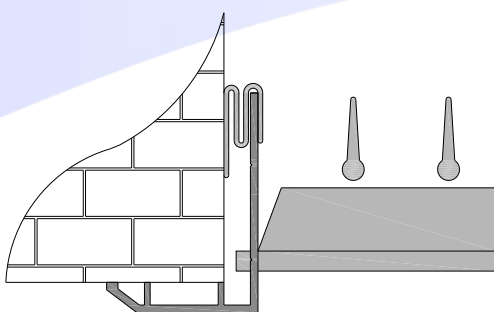

### Push-in clip method: Code suffix PC

These sprung clips are compressed when the grille is pushed into place. The outward force provided then holds the grille securely in place.

This method has the advantage of requiring no drilling or bolting, for maximum ease and causing no damage to walls.

**This fixing method is not suitable for use in ceilings.**

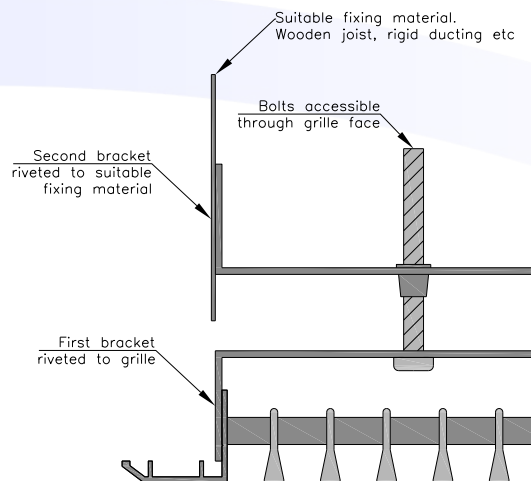

### Goalpost method: Code suffix GB

Normally used on linear slot diffusers, HVC has made this effective fixing method available to a wider range of grilles with the addition of a second bracket.

It enables the whole grille to be fully supported by, and removable from the plenum.

This method is only suitable for linear grilles with 0° blade, single / double deflection grilles, egg crate grilles, curved blade grilles, and any other grille with the removable or hinged core option specified.

# Grilles

## Frame types

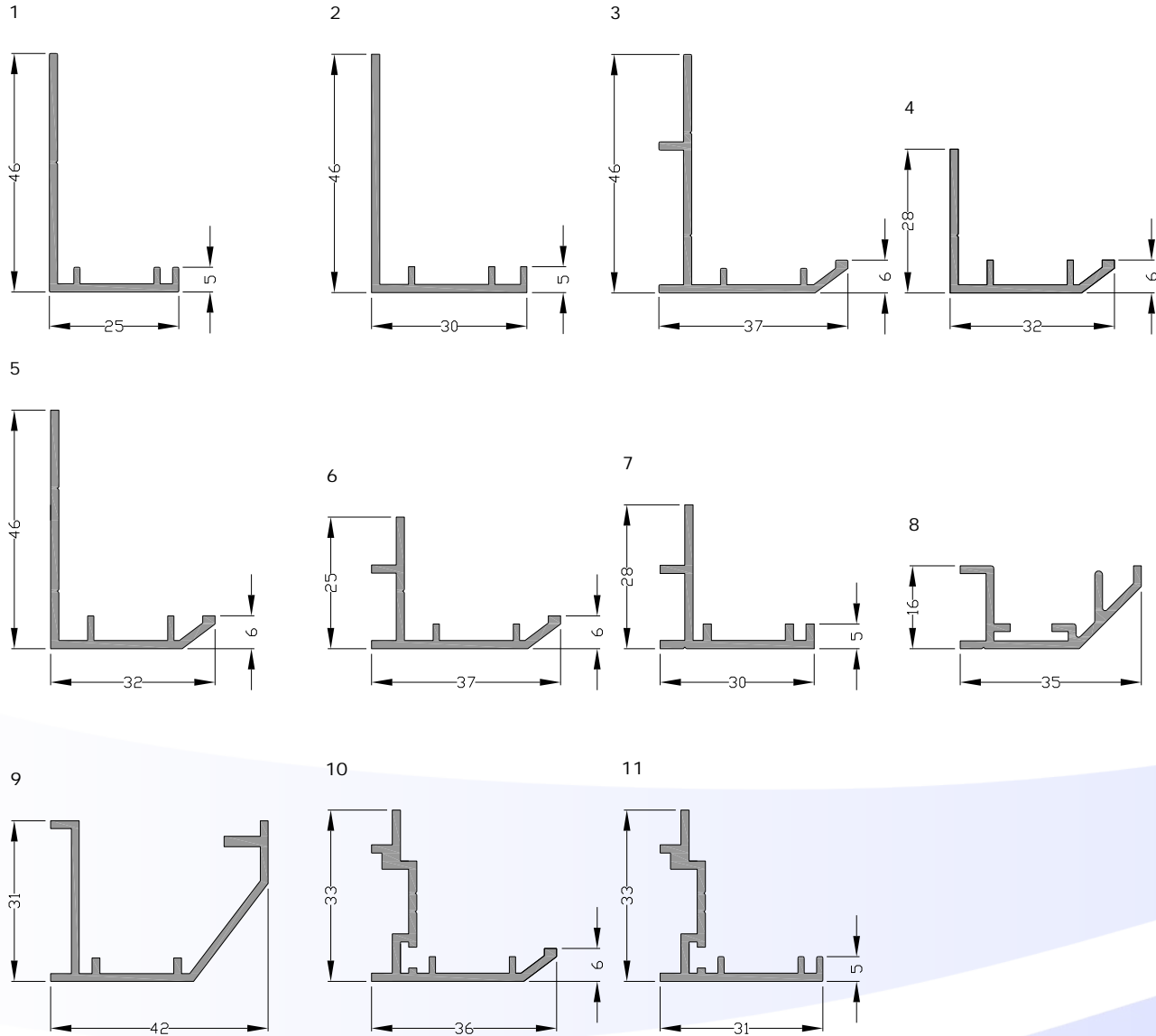

		Grille series													
Frame types		SD	DD	FB	ECG	NV	CB	LG	LGFR	CFLG	SDG	PSG	LFP	PPG	LCD
1	25mm large flat	✓	✓	✓	✗	✗	✓	✓	✓	N/A	N/A	N/A	✗	✗	STD
2	30mm flat	✓	✓	✓1 way	✗	✗	✓	✓	✓				✗	✗	✗
3	NV angle	✓	✗	✓	✓	NV1-3	✓	✓	✓				✗	✗	✗
4	32mm small bevelled	STD	✗	STD	✗	✗	STD	✓	✗				✗	✗	✗
5	32mm large bevelled	✓	STD	✓	✗	✗	✓	✓	STD				✗	✗	✗
6	37mm ECG	✗	✗	✗	STD	✗	✗	✗	✗				✗	✗	✗
7	30mm ECG	✗	✗	✗	✓	✗	✗	✗	✗				✗	✗	✗
8	Slimline surface mounted	✗	✗	✗	✓	NV4	✗	✗	✗				✗	✗	✗
9	Large surface mounted	✓	✗	✓	✓	✓	✓	✓	✗				✗	✗	✗
10	36mm bevelled LG	✗	✗	✗	✗	✗	✗	STD	✗				✗	✗	✗
11	31mm flat LG	✗	✗	✗	✗	✗	✗	✓	✗				✗	✗	✗

# Selection data

NV

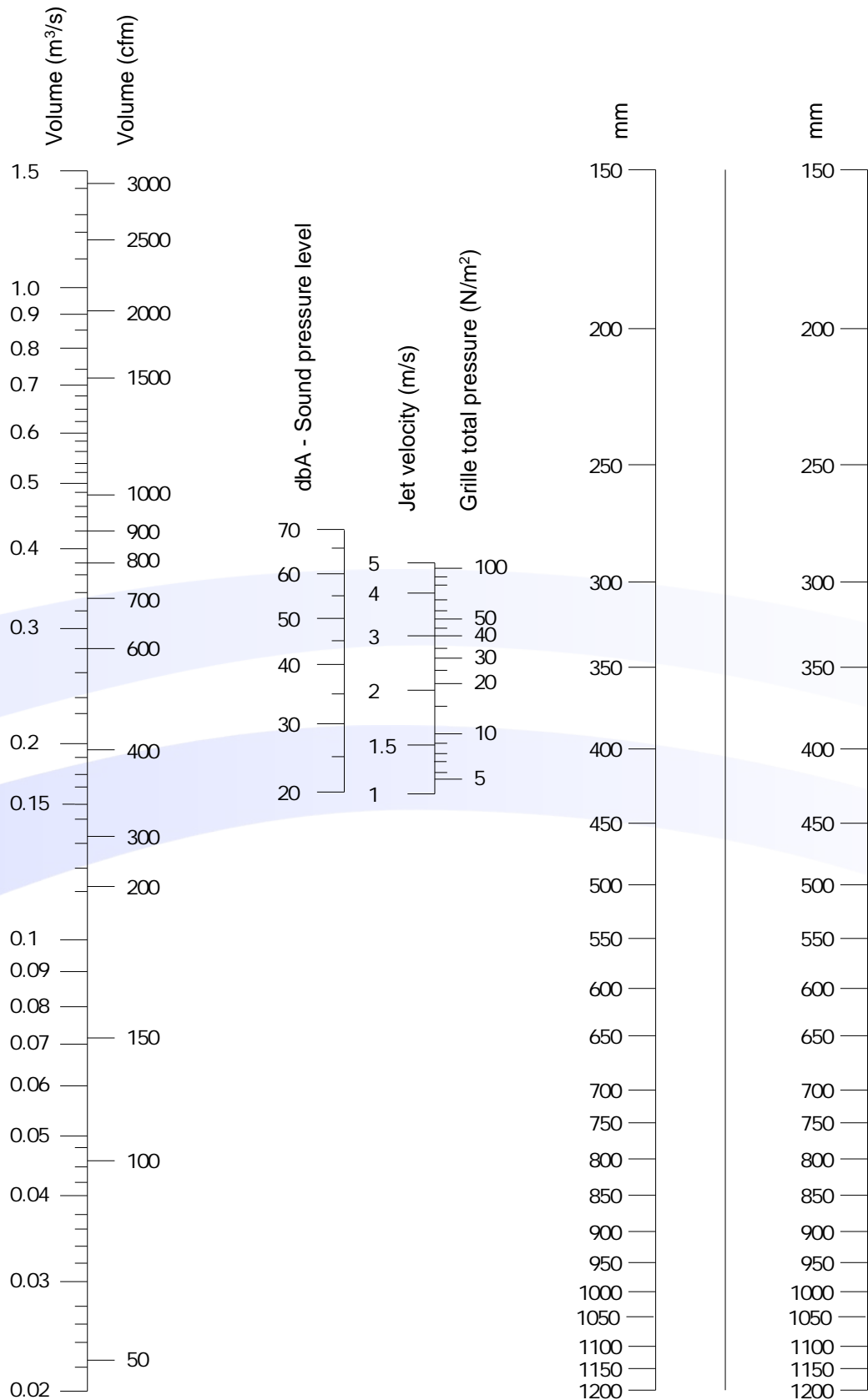



**Supplies Ltd**

Grilles & diffusers

Louvres

Fire / Fire smoke dampers

Volume control dampers



**[www.h-v-c.com](http://www.h-v-c.com)**



All details within this brochure are correct at time of going to print. However HVC's policy is one of continual product development. The right is reserved to alter any details published in this brochure without any prior notice. Any changes will appear on **[www.h-v-c.com](http://www.h-v-c.com)** as soon as is practically possible.

All information in this brochure is designed to be used for informative purposes only. HVC will not be legally bound by anything contained within this publication, or any other information distributed.

All references to companies not part of the HVC group of companies are used with the permission of their respective owners.