

T-pieces and X-pieces

TPC/XPC



Description

Ventilation T-pieces and X-pieces are available in several types and forms, depending on the size, diameter and standard or custom dimensioning. All pieces are full-bore and provided with 90-degree branches, equal to or smaller than the main duct size. Seam welds provide a neat finish and require no additional sealing.



The female-ended version is available on request (Code: TPCF).

TPC – full-bore T-piece

XPC – full-bore four-way piece

1. T-piece fabricated with an SPL collar saddle, fastened to the duct with rivets and caulked at the joints.
2. T-piece fabricated with a full-size collar saddle SPP, fastened to the bottom part with seam welds, requires no additional sealing.
3. T-piece fabricated with a SPS short segmented collar saddle, designed for non-standard duct sizes and branches sized above 400 mm.

Available materials - Product code example

- TPC-... -... -... - galvanized steel sheet
- TPC-K-... -... -... - 1.4301/304 stainless steel sheet
- TPC-K-... -... -...-316L - 1.4404/316L stainless steel sheet, molybdenum-enriched
- TPC-A-...-...-... - AW-1050A H24 aluminium sheet
- TPC-CU-...-...-... - M1E z4 copper sheet
- TPC-ZM-...-...-... - ZM310 coating (only up to a diameter of $\text{Ød}_1 = 500\text{mm}$)

Product code example

Product code: **TPC/XPC- aaa - bbb - ccc**

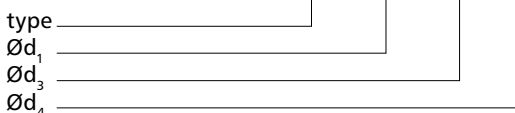

Dimensions

TPC

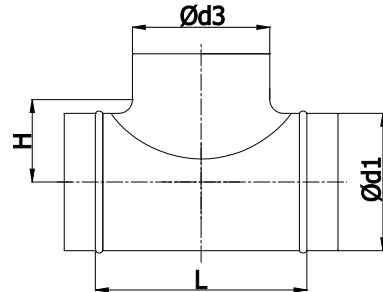

XPC

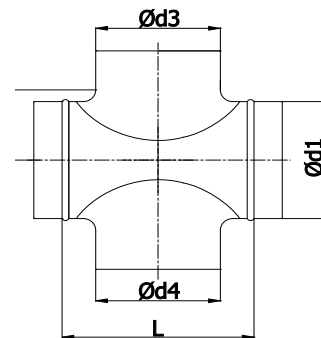

Versions

Version 1



Version 2

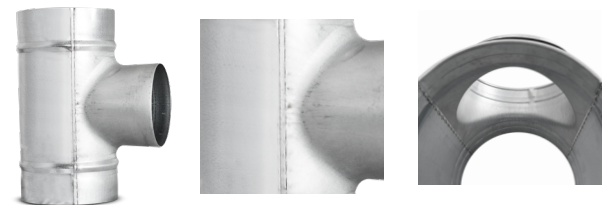

Version 3

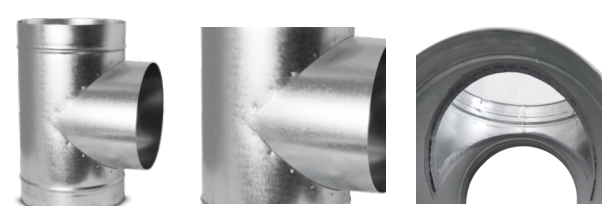

T-pieces and X-pieces

TPC/XPC

Dimensions

Ød ₁ [mm]	Ød ₃ /Ød ₄ [mm]	L [mm]	H [mm]	Weight [kg]	
				TPC	XPC
80	80 ¹	150	52	0.25	0.35
100	80 ¹	118	65	0.30	0.50
	100 ¹	164	65	0.40	0.60
125	80 ¹	154	75	0.36	0.50
	100 ¹	133	78	0.46	0.70
140	125 ¹	158	83	0.58	0.85
	80 ¹	108	82	0.38	0.50
150	100 ¹	133	85	0.50	0.74
	125 ¹	158	90	0.65	0.96
	140 ³	168	95	0.70	0.99
160	150 ¹	200	95	0.70	1.02
	80 ¹	118	92	0.44	0.56
	100 ¹	128	95	0.55	0.82
	125 ¹	158	100	0.68	1.05
	140 ³	168	100	0.75	1.07
180	150 ³	188	100	0.75	1.09
	160 ¹	208	105	0.80	1.15
	80 ¹	118	102	0.50	0.60
	100 ¹	128	105	0.65	0.85
	125 ¹	158	110	0.77	1.08
	140 ³	168	110	0.80	1.10
	150 ³	210	110	0.80	1.12
200	160 ¹	258	115	0.92	1.14
	180 ³	218	115	1.06	1.45
	80 ¹	123	112	0.55	0.66
	100 ¹	128	115	0.65	0.92
	125 ¹	174	115	0.79	1.17
	140 ³	168	120	0.83	1.20
	150 ¹	246	120	0.88	1.23
224	160 ¹	258	125	0.95	1.45
	180 ³	273	125	1.15	1.64
	200 ¹	248	125	1.25	1.70
	224 ³	274	137	1.46	2.06

Ød ₁ [mm]	Ød ₃ /Ød ₄ [mm]	L [mm]	H [mm]	Weight [kg]	
				TPC	XPC
224	80 ¹	123	124	0.60	0.70
	100 ¹	158	127	0.78	0.98
125 ¹	158	132	0.90	1.15	
140 ³	168	132	0.98	1.34	
150 ³	210	132	0.98	1.36	
160 ¹	258	137	1.00	1.55	
180 ³	230	137	1.20	1.74	
200 ¹	248	137	1.25	1.83	
224 ³	274	137	1.46	2.06	
250	80 ¹	109	137	0.73	0.96
	100 ¹	148	140	0.83	1.17
	125 ¹	158	145	0.90	1.27
	140 ³	180	145	1.12	1.50
	150 ¹	246	145	1.12	1.53
	160 ¹	258	150	1.19	1.70
	180 ³	230	150	1.40	2.00
280	200 ¹	248	150	1.40	2.05
	224 ³	274	150	1.60	2.40
	250 ¹	278	150	1.77	2.50
	80 ³	130	152	0.80	1.15
	100 ³	150	155	0.93	1.27
	125 ¹	158	160	1.05	1.40
	140 ³	180	160	1.20	1.68
	150 ³	210	160	1.20	1.70
	160 ³	220	165	1.28	1.84
	180 ³	230	165	1.45	2.00
300	200 ¹	248	165	1.50	2.05
	224 ³	272	165	1.64	2.35
	80 ³	130	162	0.90	1.40
	100 ³	150	165	1.00	1.42
	125 ¹	158	170	1.07	1.50
	140 ³	180	170	1.25	1.77
	150 ¹	248	170	1.25	1.80
	160 ¹	258	175	1.35	1.98
	180 ³	230	175	1.55	2.15
	200 ¹	248	175	1.58	2.20
224 ³	274	175	1.73	2.46	
250 ¹	298	175	1.94	2.60	

Dimensions

$\varnothing d_1$ [mm]	$\varnothing d_3 / \varnothing d_4$ [mm]	L [mm]	H [mm]	Weight [kg]	
				TPC	XPC
315	80 ³	130	170	1.00	1.41
	100 ³	150	173	1.02	1.43
	125 ¹	158	178	1.10	1.53
	140 ³	180	178	1.35	1.62
	150 ¹	248	178	1.35	1.65
	160 ¹	258	182	1.35	2.00
	180 ³	230	182	1.62	2.22
	200 ¹	42	182	1.65	2.26
	224 ³	274	182	1.80	2.55
	250 ¹	298	182	1.95	2.67
	315 ¹	428	182	2.80	3.66
355	100 ³	110	193	1.32	2.00
	125 ³	135	198	1.45	2.10
	160 ³	170	203	1.70	2.25
	200 ¹	300	203	2.10	2.75
	224 ³	244	203	2.36	3.10
	250 ¹	300	203	2.45	3.20
	315 ¹	705	203	3.10	4.20
	400 ¹	110	215	1.80	2.20
400	125 ³	135	220	1.90	2.40
	160 ³	170	225	2.20	2.80
	200 ¹	300	225	2.60	3.20
	224 ¹	244	225	2.80	3.60
	250 ¹	360	225	3.00	3.75
	315 ³	335	225	3.55	4.38
	400 ³	420	225	4.60	5.90
	450 ¹	125 ³	135	245	2.65
450	160 ³	200	250	3.00	3.70
	200 ³	220	250	3.50	4.20
	250 ³	270	250	4.00	4.80
	315 ³	335	250	4.50	5.30
	400 ³	420	250	5.60	6.80
500	125 ³	135	270	3.00	3.80
	160 ³	180	275	3.30	4.10
	200 ³	220	275	3.80	4.60
	250 ³	270	275	4.4	5.2
	315 ³	335	275	5.0	5.8
400 ³	420	275	6.3	7.6	

$\varnothing d_1$ [mm]	$\varnothing d_3 / \varnothing d_4$ [mm]	L [mm]	H [mm]	Weight [kg]	
				TPC	XPC
560	200 ³	220	305	4.3	5.7
	250 ³	270	305	4.8	6.3
	315 ³	315	305	5.6	7.2
	400 ³	420	305	6.9	9.3
600	200 ³	220	325	4.5	6.1
	250 ³	270	325	4.9	6.7
	315 ³	335	325	5.9	7.6
630	400 ³	420	325	7.3	9.8
	200 ³	240	340	4.8	6.4
	250 ³	270	340	5.4	7.0
630	315 ³	335	340	6.3	8.2
	400 ³	420	340	7.7	10.2
	710	160 ³	230	415	5.5
710	200 ³	270	415	6.0	6.3
	250 ³	320	415	6.6	6.7
	315 ³	385	435	7.5	8.0
	400 ³	484	435	8.5	9.6
	450 ³	520	475	9.4	10.9
800	160 ³	230	460	6.2	6.8
	200 ³	270	460	6.8	7.5
	250 ³	320	460	7.4	8.0
	315 ³	385	480	8.4	9.3
	400 ³	470	480	9.5	10.5
800	450 ³	520	520	10.5	11.6
	500 ³	570	520	11.2	12.0
	560 ³	630	520	11.9	13.1

T-pieces and X-pieces

TPCL/XPCL/TPC/XPC

Technical specifications

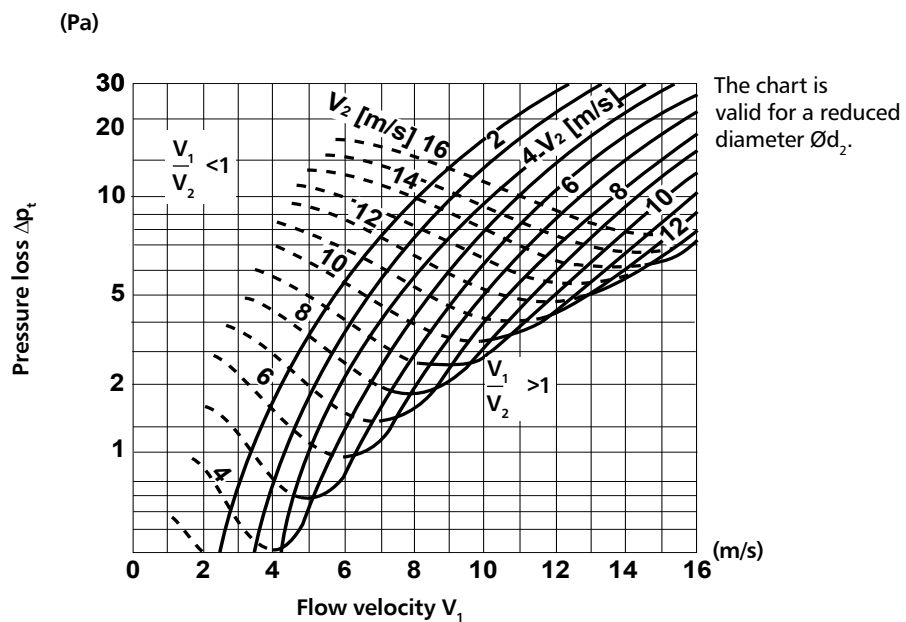
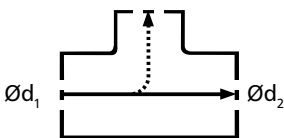
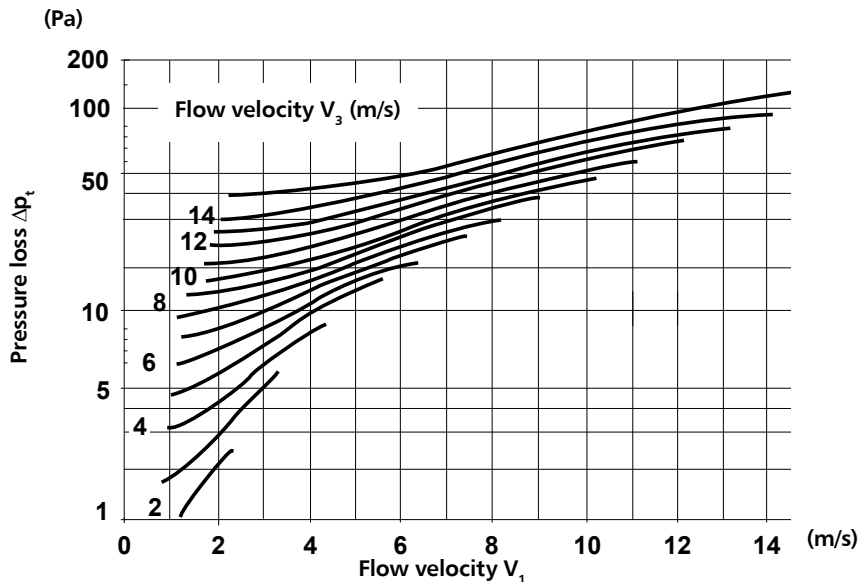
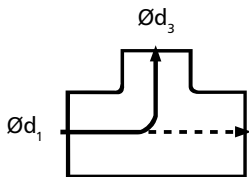

V_1 – average flow velocity across d_1
 V_2 – average flow velocity across d_2
 V_3 – average flow velocity across d_3

T-pieces and X-pieces

TPCL/XPCL/TPC/XPC

Technical specifications

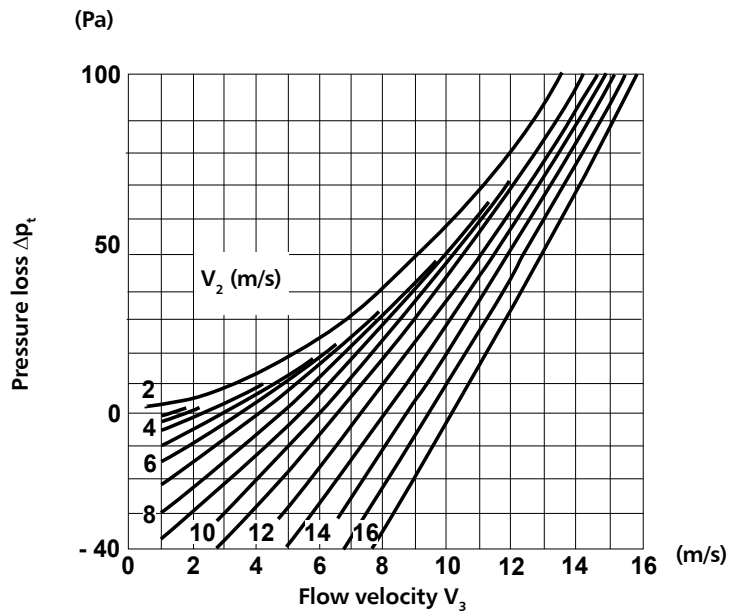
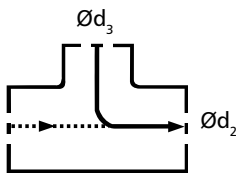
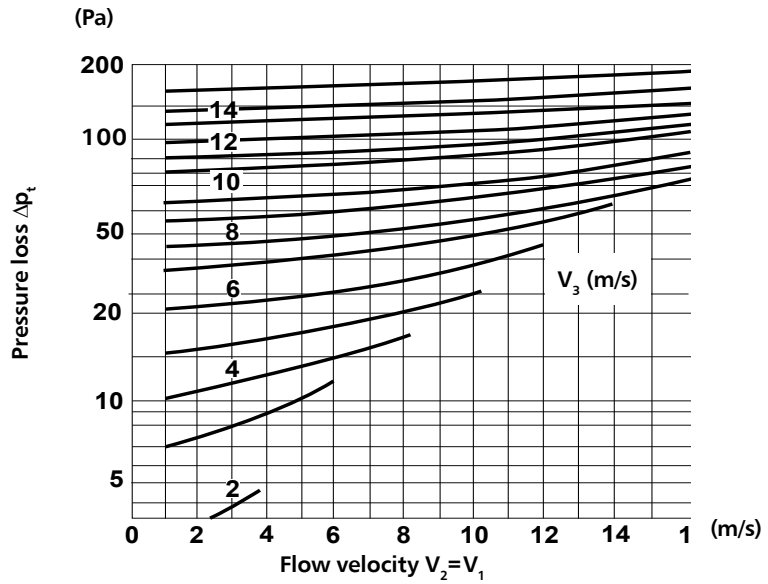
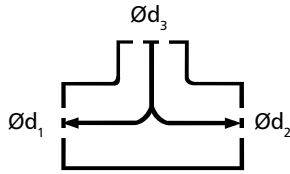

V_1 – average flow velocity across d_1
 V_2 – average flow velocity across d_2
 V_3 – average flow velocity across d_3

T-pieces and X-pieces

TPCL/XPCL/TPC/XPC

Technical specifications

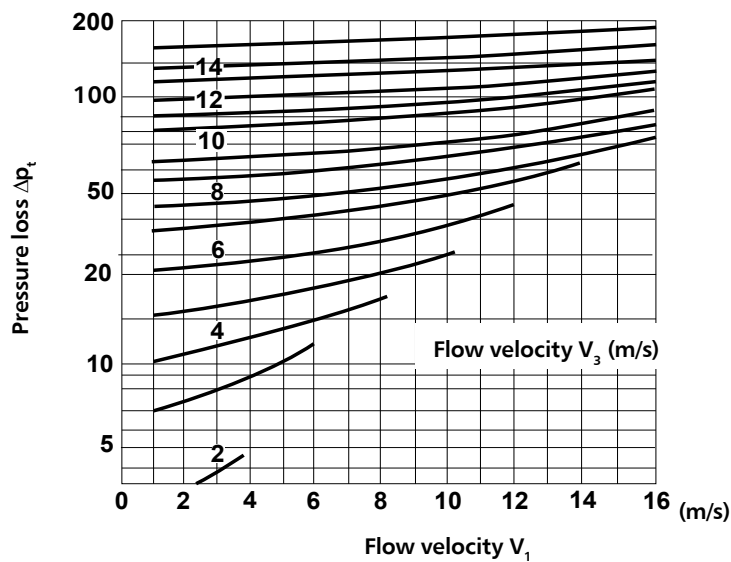
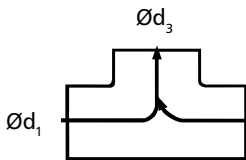
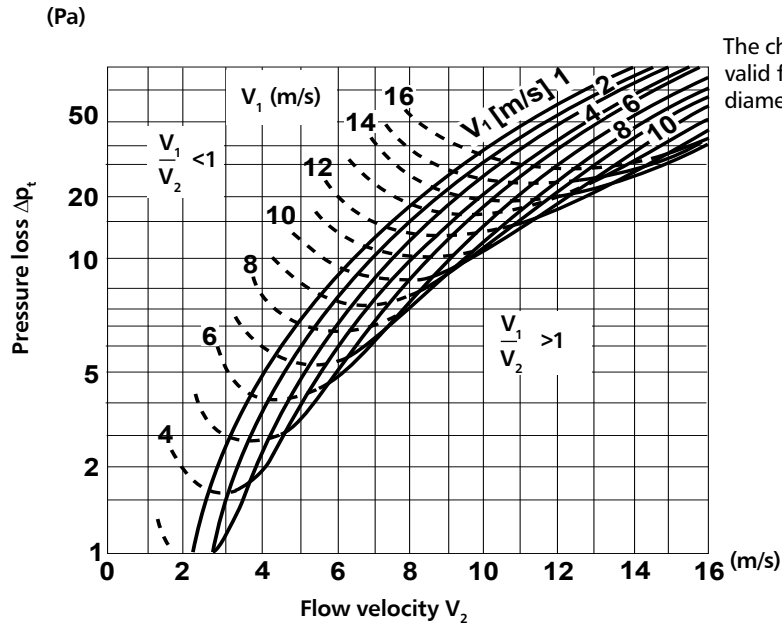
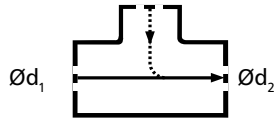

- V_1 – average flow velocity across d_1
- V_2 – average flow velocity across d_2
- V_3 – average flow velocity across d_3